



Single Board Computer
EBC 500 Series
User's Manual

Oct-20-2006 Build
Feb-30-2007 Update

***User's Manual is subject to change without prior notice.
For any update, please visit our website: www.nexcom.com***

Preface

Copyright

This publication, including all photographs, illustrations and software, is protected under international copyright laws, with all rights reserved. No part of this manual maybe reproduced, copied, translated or transmitted in any form or by any means without the prior written consent from NEXCOM International Co., Ltd.

Version 1.1

Copyright 2006

Disclaimer

The information in this document is subject to change without prior notice and does not represent commitment from NEXCOM International Co., LTD. However, users may update their knowledge of any product in use by constantly checking its manual posted on our website: <http://www.nexcom.com>. NEXCOM shall not be liable for direct, indirect, special, incidental, or consequential damages arising out of the use of any product, nor for any infringements upon the rights of third parties, which may result from such use. Any implied warranties of merchantability of fitness for any particular purpose is also disclaimed.

Acknowledgements

The EBC 500 series is a trademark of NEXCOM international CO., LTD. All other product names mentioned herein are registered trademarks of their respective owners.

Regulatory Compliance Statements

This section provides the FCC compliance statement for Class A devices and describes how to keep the system CE compliant.

Federal Communications Commission (FCC) For Class A Device

This equipment has been tested and verified to comply with the limits for a Class A digital device, pursuant to Part 15 of FCC Rules. These limits are designed to provide reasonable protection against harmful interference when the equipment is operated in a commercial environment. This equipment generates, uses, and can radiate radio frequency energy and, if not installed and used in accordance with the instructions, may cause harmful interference to radio communications. Operation of this equipment in a residential area (domestic environment) is likely to cause harmful interference, in which case the user will be required to correct the interference (take adequate measures) at their own expense.

CE Certification

The product(s) described in this manual complies with all applicable European Union (CE) directives if it has a CE marking. For computer systems to remain CE compliant, only CE-compliant parts may be used. Maintaining CE compliance also requires proper cable and cabling techniques.

WARNINGS

Read and adhere to all warnings, cautions, and notices in this guide and the documentation supplied with the chassis, power supply, and accessory modules. If the instructions for the chassis and power supply are inconsistent with these instructions or the instructions for accessory modules, contact the supplier to find out how you can ensure that your computer meets safety and regulatory requirements.

CAUTION

Electrostatic discharge (ESD) can damage NSA components. Do the described procedures only at an ESD workstation. If no such station is available, you can provide some ESD protection by wearing an antistatic wrist strap and attaching it to a metal part of the computer chassis.

Safety Information

Before installing and using the EBC 500, note the following precautions:

- Read all instructions carefully.
- Do not place the unit on an unstable surface, cart, or stand.
- Follow all warnings and cautions in this manual.
- When replacing parts, ensure that your service technician uses parts specified by the manufacturer.
- Avoid using the system near water, in direct sunlight, or near a hearing device.

Table of Content

Preface	2
Copyright	2
Disclaimer	2
Acknowledgements	2
Regulatory Compliance Statements	2
Federal Communications Commission (FCC) For Class A Device	3
CE Certification	3
Safety Information	3
Table of Content	3
Chapter 1 General Information	
1.1 Main Feature	5
1.2 Specifications	7
1.3 Power Consumption Measurement	9
1.4 Board Layout	11
1.5 Board Dimensions	11
Chapter 2 Jumper Setting	
2.1 Before You Begin	13
2.2 Precautions	13
2.3 Setting Jumpers	14
2.4 Location of Jumpers	15
2.5 Function of Jumper	15
Chapter 3 Expansion	
3.1 System Memory	30
3.2 Installing DIMM	30
3.3 Installing Compact Flash	32

Chapter 1

General Information

1.1 Product Feature

- ◆ Intel Core Solo & Core Duo and Core 2 Duo Processor Family support
- ◆ Intel 945GM Chipsets
- ◆ Two 240-pin DDR2 DIMM Socket support un-buffered non-ECC DDR2 400/533/667 up to 4GB
- ◆ Intel 82573L PCI Express Gigabit LAN X 2
- ◆ Support LVDS /VGA Display and one x16 PCI Express slot
- ◆ CompactFlash Socket

Product Overview:

EBC 500 is a 5.25" embedded board featuring Intel Core Solo, Core Duo and Core 2 Duo processor with 533/667 MHz FSB; speed up to 2.33 (2.0) GHz.

The EBC 500 offers high performance and various processors and PCI Express; versatile display and I/O port selections, which is the best solution for advanced embedded applications.

Block Diagram:

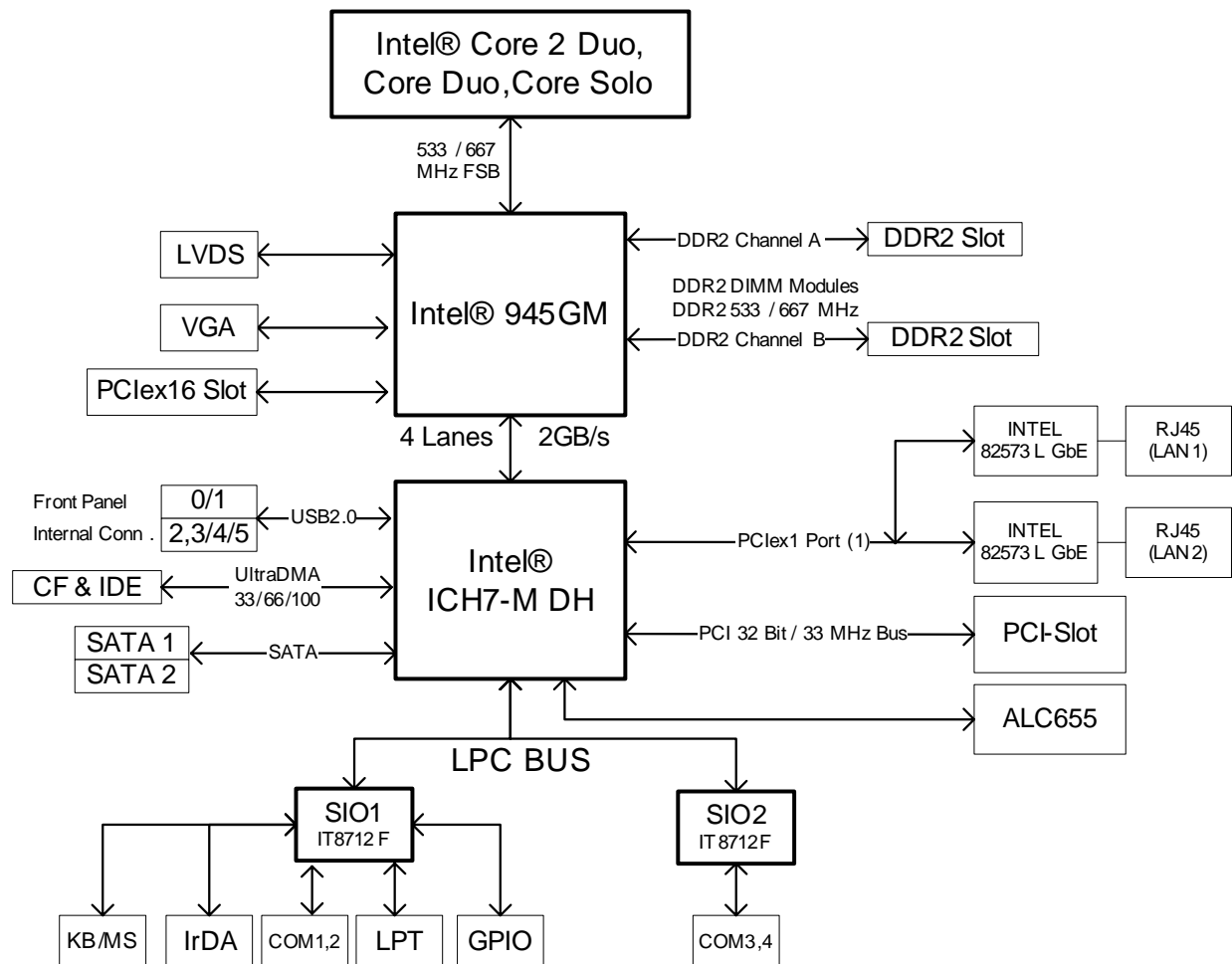

1.2 Specification:

General	
CPU	<ul style="list-style-type: none"> ● Intel® Core Solo and Core Duo family processors ● Core 2 Duo family CPU (optional)
Front Side Bus	<ul style="list-style-type: none"> ● 533/667 MHz
Chipset	<ul style="list-style-type: none"> ● Intel 945GM and ICH7-M DH
Memory	<ul style="list-style-type: none"> ● 2 x 240-pin DDR2 DIMM socket, up to 4GB un-buffered non-ECC DDR2 533/667 SDRAM
Super I/O	<ul style="list-style-type: none"> ● ITE 8712F
BIOS	<ul style="list-style-type: none"> ● Award system BIOS ● Plug & Play support ● Advanced Power Management and Advanced Configuration & Power Interface support ● 4M bits flash ROM
Expansion interface	<ul style="list-style-type: none"> ● 1 x PCI Slot ● 1 x PCI Express x 16 Slot
Dimensions (Lx W) mm/inch	<ul style="list-style-type: none"> ● 203mm(L) x 143mm(W)
System Management	
Watchdog Timer	<ul style="list-style-type: none"> ● 1 minute increments from 1 to 255 minutes ● 1 second increments from 1 to 255 seconds ● Tolerance 15% under room temperature 25°C
Monitoring	<ul style="list-style-type: none"> ● Derived from Super IO to support system monitor. ● Monitoring of 5 voltages, 3 temperature and 3 fans Speed. 5 voltage (For +3.3V, +5V, +12V, Vcore and +2.5V) 3 Temperatures (CPU, two external Temperature Sensor) 3 FANS speed (CPU and System FANS)
Display	
Chipset	<ul style="list-style-type: none"> ● Intel® 945GM integrated graphics solution w/ Intel® Extreme Graphics 2 technology
Display Memory	<ul style="list-style-type: none"> ● Up to 64 MB of dynamic video memory allocation
Display interface and Resolution	<ul style="list-style-type: none"> ● CRT- Analog Display Support ● Drive a standard progressive scan analog monitor with pixel resolution up to 1400 x 1050
	<ul style="list-style-type: none"> ● LVDS - LFP (local flat panel) LVDS interface ● Single- or dual-pixel LVDS panel support
	<ul style="list-style-type: none"> ● CCFL x1 for LCD Panel Backlight Inverter Power Pin 2,3 support 12VDC power source for inverter: Max. 12VDC@2A for each
Ethernet	
Controller	<ul style="list-style-type: none"> ● Intel® 82573L PCI Express Gigabit Ethernet Controller x 2 supporting two GbE LAN ports ● Support Boot From LAN (PXE) ● Support Wake on LAN (When 5Vsb power available). (LAN1 only)
Interface	<ul style="list-style-type: none"> ● 2 x RJ45 with LED connector
LED	<ul style="list-style-type: none"> ● Active, Link 100, and 1000 LAN LED ● LAN Status LED defined: 10: LED Off / 100: Green LED / 1000: Orange LED ● Extra (External) LED: 2 x 4 pin header

Audio	
AC97 Audio CODEC	<ul style="list-style-type: none"> ● Realtek RTL655 CODEC for AC97 v2.1 CODEC ● Line in with pin header ● Microphone in and Speaker out Interface
I/O Interface	
USB 2.0	<ul style="list-style-type: none"> ● 6 x USB 2.0 port (2 on front, 4 on Board by one 2.0 mm JST Connectors), bandwidth: 480 Mb/s
Serial ports	<ul style="list-style-type: none"> ● SIO× 4, support RS-232 with pin headers ● 1 x3-pin jumper to switch 5V and 12V power source
Parallel ports	<ul style="list-style-type: none"> ● 1 x Box header 26-pin connector
PS/2	<ul style="list-style-type: none"> ● 1 x PS/2 connector for Keyboard and Mouse
GPIO	<ul style="list-style-type: none"> ● 8 GPIO lines via header (GPI 0~3 and GPO 0~3); GPO0 and GPO1 could be connected to LED for programmable feature ● TTL Level (0/5V)
FAN	<ul style="list-style-type: none"> ● 1x 4-pin FAN JST connector (for CPU) ● 2x 3-pin FAN connector x 2 (for System)
IrDA	On board pin header for IrDA Tx Rx
Others	<ul style="list-style-type: none"> ● On Board buzzer ● Power LED/HDD Power LED ● SMBus 2.0 controller (2 pin header) ● On board 2 pin header for reset (for power on button switch)
On-board RTC	
	<ul style="list-style-type: none"> ● On-chip RTC with battery back up ● External Lithium battery x 1 ● RTC Tolerance less than 2sec (24 hours) under 25°C environment
Storage Support	
CF	<ul style="list-style-type: none"> ● 1x Internal CompactFlash socket ● Support One Type I& II Compact Flash Card (Primary Master)
SATA	<ul style="list-style-type: none"> ● 2 x SATA ports, support Raid 0,1, bandwidth: 150 MB/s
IDE	<ul style="list-style-type: none"> ● 1 x 44-pin IDE connector
Disk on Module	<ul style="list-style-type: none"> ● 1 x 2-pin Jst power (+5V,GND) for DOM
Power Supply	
Type	<ul style="list-style-type: none"> ● Support both AT and ATX Mode ● Factory default setting is AT mode
ATX mode	<ul style="list-style-type: none"> ● +5V / -5V / 5Vsb Power In (+12V/-12V for PC 104 plus) ● When Change to ATX Mode, the BIOS default setting is as follow: POWER -SUPPLY TYPE → [ATX] AUTO PWR-FAILURE RESUME → [ON]
AT mode	<ul style="list-style-type: none"> ● +5V Power in ● No Power On push Button, Software Shutdown function and LAN remote wake up
Power consumption	43.2 W in 12V, 121.2 W in 5V, and 11.5W in 5Vsb
Environment	
Operating Temperature	0°C ~ 60°C
Storage Temperature	-20°C to 85°C
Relative Humidity	<ul style="list-style-type: none"> ● Operating 10%~90%, non-condensing ● Non-operating 5%~95%, non-condensing
Certifications	
	CE approval FCC Class A

Ordering Information:

EBC 500 (P/N: 1E00050000X0)	5.25" Embedded Board supporting Intel Core Solo, Core Duo and Core 2 Duo CPU w/VGA/ Dual LVDS/Audio/4 COMs/6 USB2.0 /Dual Gigabit LAN
---------------------------------------	---

1.3 Power Consumption Measurement

<i>Model :</i>	<i>EBC500</i>	<i>PCB Ver :</i>	<i>B</i>
<i>In Date :</i>	<i>09/06/2006</i>	<i>Out Date :</i>	<i>09/25/2006</i>
<i>In Time :</i>	<i>14:41</i>	<i>Out Time :</i>	<i>10:46</i>
		<i>BIOS Ver :</i>	<i>C-002</i>
		<i>Testing Result</i>	<i>Pass</i>

Test Environment

<i>Operating System</i>	<i><English>Windows XP-Professional-5.01.2600+SP2</i>
<i>Processor</i>	<i>Intel Pentium-M 2.0GHz/667MHz/ Core Duo T2500</i>
	<i>Intel Pentium-M 2.16GHz/667MHz/ Core Duo T2600</i>
	<i>Intel Pentium-M 2.17GHz/667MHz/ Core 2 Duo T7400 (Engineer Sample)</i>
<i>Memory</i>	<i>Kingston hynix HY5PS12821 512MB/DDRII-533/Non-ECC x 2</i>
	<i>UNIGE ELPIDA E5108.AG-6E-E 1GB/DDRII-667/Non-ECC x 2</i>
<i>IDE HDD Device Type</i>	<i>HITACHI HTS541040G9.AT00 40GB/ATA100/5400RPM</i>
<i>S-ATA HDD Device Type</i>	<i>HITACHI HTS541040G9S.A00 40GB/ATA100/5400RPM x 2</i>
<i>Floppy Device Type</i>	<i>TEAC USB-FS3502</i>
<i>CD-ROM Device Type</i>	<i>Quanta SCR-242</i>
<i>PCI SCSI Card</i>	<i>Tekram DC-395UW</i>
<i>SCSI HDD Device Type</i>	<i>Seagate ST39205LW</i>
<i>USB Floppy Device Type</i>	<i>TEAC USB-F3502</i>
<i>USB HDD Device Type</i>	<i>IBM DARA-20600 6GB/ATA-66/4200RPM</i>
	<i>HITACHI HTS424040M9.AT00 40GB/ATA100/4200rpm</i>
<i>USB Flash Device Type</i>	<i>AD.ATA 512MB</i>
	<i>Transcend JF110 256MB</i>
<i>USB CD-ROM Device Type</i>	<i>ASUS CRW-4012A-U</i>
<i>Power Supply</i>	<i>Seventeam ST-300BLV 300W</i>
<i>Monitor</i>	<i>LEMEL M780</i>

Power Supply Type : *Seventeam ST-300BLV 300W*

CPU Type: *Intel Pentium-M 2.0GHz/667MHz/ Core Duo T2500*

<i>Low AC Line 110~115V: (System-Only)</i>	<i>+12V</i>	<i>+5V</i>	<i>3.3V</i>	<i>5V/SB</i>
<i>Full-Loading Mode (A)</i>	<i>4.66 (A)</i>	<i>5.85 (A)</i>	<i>0.21 (A)</i>	<i>0.22 (A)</i>
<i>Light-Loading Mode (A)</i>	<i>0.53 (A)</i>	<i>2.90 (A)</i>	<i>0.19 (A)</i>	<i>0.20 (A)</i>
<i>Standby Mode (HDD Drive Power-Down) (A)</i>	<i>0.76 (A)</i>	<i>1.84 (A)</i>	<i>0.20 (A)</i>	<i>0.19 (A)</i>
<i>Suspend Mode (S4)</i>	<i>0.20 (A)</i>	<i>0.20 (A)</i>	<i>0.19 (A)</i>	<i>0.36 (A)</i>

Power Supply Type : *Seventeam ST-300BLV 300W*

CPU Type: *Intel Pentium-M 2.16GHz/667MHz/ Core Duo T2600*

<i>Low AC Line 110~115V: (System-Only)</i>	<i>+12V</i>	<i>+5V</i>	<i>3.3V</i>	<i>5V/SB</i>
<i>Full-Loading Mode (A)</i>	<i>4.46 (A)</i>	<i>5.35 (A)</i>	<i>0.19(A)</i>	<i>0.20(A)</i>
<i>Light-Loading Mode (A)</i>	<i>1.11(A)</i>	<i>2.96(A)</i>	<i>0.22(A)</i>	<i>0.22 (A)</i>
<i>Standby Mode (HDD Drive Power-Down) (A)</i>	<i>0.96 (A)</i>	<i>1.73 (A)</i>	<i>0.21 (A)</i>	<i>0.20 (A)</i>
<i>Suspend Mode (S4)</i>	<i>0.22 (A)</i>	<i>0.22 (A)</i>	<i>0.23 (A)</i>	<i>0.38 (A)</i>

Power Supply Type : *Seventeam ST-300BLV 300W*

CPU Type: *Intel Pentium-M 2.17GHz/667MHz/ Core Duo T7400*

<i>Low AC Line 110~115V: (System-Only)</i>	<i>+12V</i>	<i>+5V</i>	<i>3.3V</i>	<i>5V/SB</i>
<i>Full-Loading Mode (A)</i>	<i>3.25 (A)</i>	<i>4.97 (A)</i>	<i>0.03 (A)</i>	<i>0.02 (A)</i>
<i>Light-Loading Mode (A)</i>	<i>0.40 (A)</i>	<i>2.97 (A)</i>	<i>0.03 (A)</i>	<i>0.03 (A)</i>
<i>Standby Mode (HDD Drive Power-Down) (A)</i>	<i>0.39 (A)</i>	<i>2.60 (A)</i>	<i>0.01 (A)</i>	<i>0.06 (A)</i>
<i>Suspend Mode (S4)</i>	<i>0.03 (A)</i>	<i>0.05 (A)</i>	<i>0.01 (A)</i>	<i>0.11 (A)</i>

The Data is based on fully possible configurations installed on EBC 500 include the Add-on Card, and peripherals such as USB devices, SCSI Card and SCSI HDD.

Test Criteria:

1. Test configuration is include EBC500, HDD, CD-ROM, and FDD.
2. Full loading mode should utilize CPU 100% with run Burn-in test program.
3. Light loading mode will utilize CPU loading below 5%, and there is no data or application running.

1.4 Board Layout

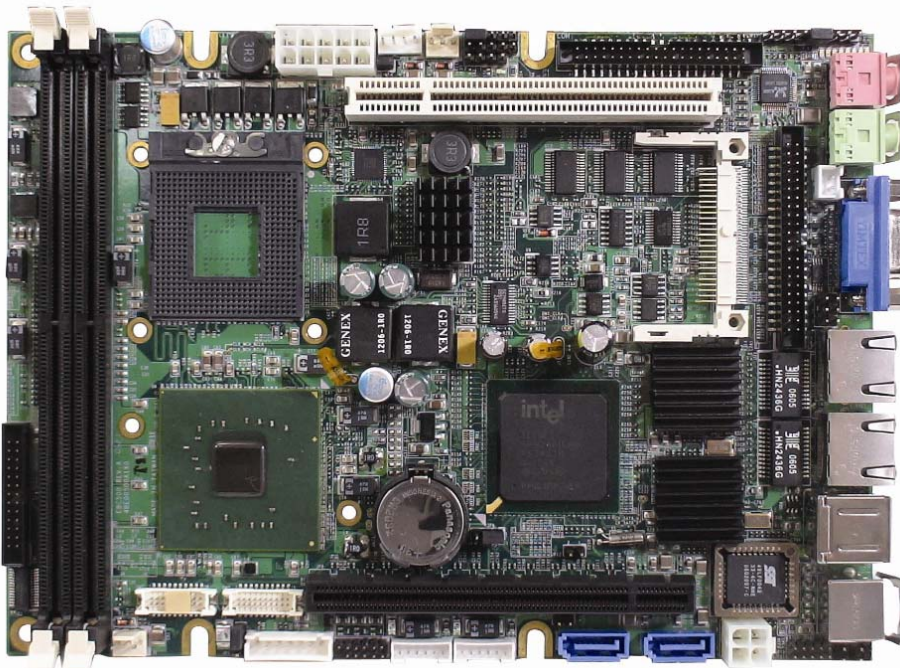

Figure 1.2: Overview

1.5 Board Dimensions

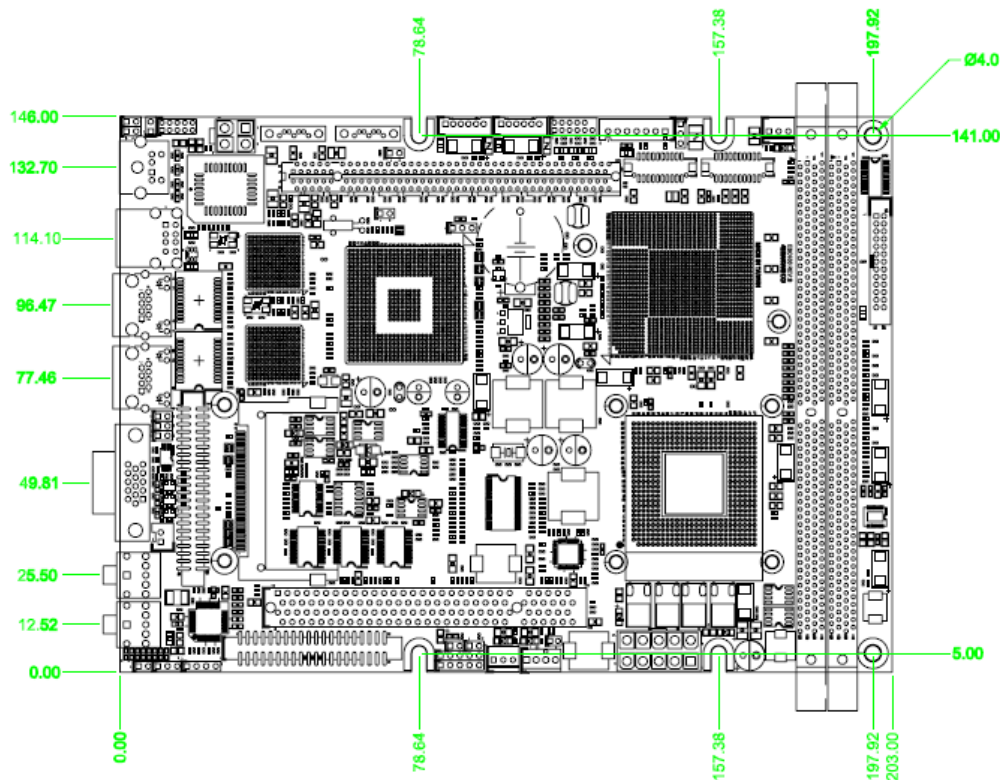

Figure 1.3:
Mechanical
Drawing

Chapter 2

Jumper Setting

This chapter of the User's Manual describes how to set jumpers.

Note: The procedures that follow are generic for all EBC 500 series.

2.1 Before You Begin

Ensure you have a stable, clean working environment. Dust and dirt can get into components and cause a malfunction. Use containers to keep small components separated.

Adequate lighting and proper tools can prevent you from accidentally damaging the internal components. Most of the procedures that follow require only a few simple tools, including the following:

- A Philips screwdriver
- A flat-tipped screwdriver
- A set of jewelers Screwdrivers
- A grounding strap
- An anti-static pad

Using your fingers can disconnect most of the connections. It is recommended that you do not use needle-nosed pliers to disconnect connections as these can damage the soft metal or plastic parts of the connectors.

Before working on internal components, make sure that the power is off. Ground yourself before touching any internal components, by touching a metal object. Static electricity can damage many of the electronic components. Humid environment tend to have less static electricity than dry environments. A grounding strap is warranted whenever danger of static electricity exists.

2.2 Precautions

Computer components and electronic circuit boards can be damaged by discharges of static electricity.

Working on the computers that are still connected to a power supply can be extremely dangerous. Follow the guidelines below to avoid damage to your computer or yourself:

- Always disconnect the unit from the power outlet whenever you are working inside the case.
- If possible, wear a grounded wrist strap when you are working inside the computer case. Alternatively, discharge any static electricity by touching the bare metal chassis of the unit case, or the bare metal body of any other grounded appliance.
- Hold electronic circuit boards (such as the EBC 500 board) by the edges only. Do not touch the components on the board unless it is necessary to do so. Don't flex or stress the circuit

board.

- Leave all components inside the static-proof packaging that they shipped with until they are ready for installation.
- Use correct screws and do not over tighten screws.

2.3 Setting Jumpers

A jumper is the simplest kind of electric switch. It consists of two metal pins and a cap. When setting the jumpers, ensure that the jumper caps are placed on the correct pins. When the jumper cap is placed on both pins, the jumper is **SHORT**. If you remove the jumper cap, or place the jumper cap on just one pin, the jumper is **OPEN**. Please see the following illustrations

<p>The illustrations on the right show a 2-pin jumper. When the jumper cap is placed on both pins, the jumper is SHORT. If you remove the jumper cap, or place the jumper cap on just one pin, the jumper is OPEN.</p>		
	<p>Open (Off)</p>	<p>Short (On)</p>
<p>These illustrations show a 3-pin jumper. Pins 1 and 2 are SHORT.</p>		

Table 2-1: Setting Jumpers

2.4 Location of Jumpers

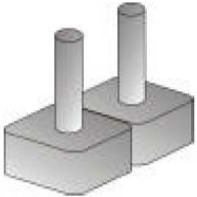
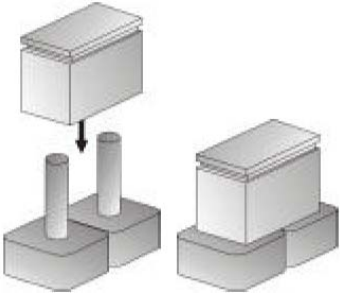
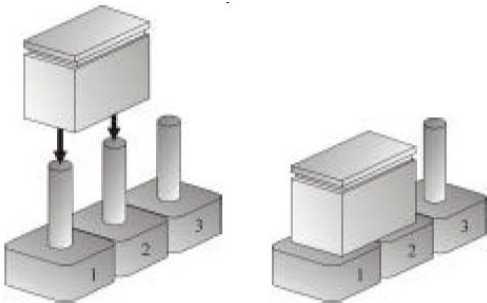
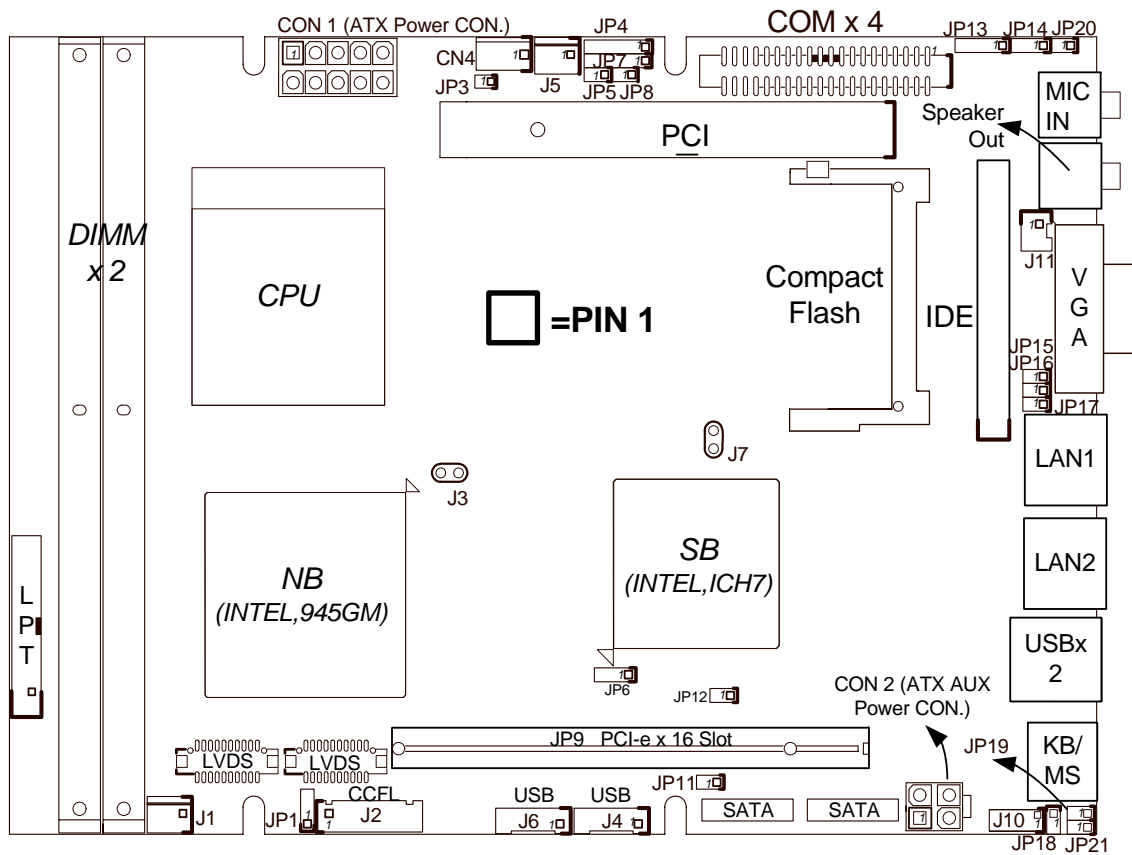

Figure 2-1: Jumper Location

2.5 Functions of Jumpers and Connectors

- **SATA1/SATA0 connector (J8, J9)**

A . Connector size : 7 Pin , 1.27mm , 180°, SATA Connector

B . Connector location

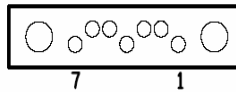

C. Connector pin definition

Pin	Definition	Pin	Definition
1	GND	5	SATA_RXN
2	SATA_TXP	6	SATA_RXP
3	SATA_TXN	7	GND
4	GND		

● **PIO Connector (CN1)**

A . Connector size : 2 X 13 = 26 Pin ,2.0 mm, 180° ,BOX Header

B . Connector location

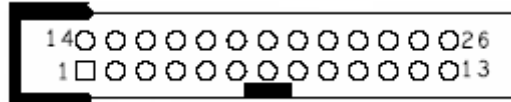

C . Connector pin definition

Pin	Definition	Pin	Definition
1	Line Print Strobe	14	Auto Feed#
2	Parallel Data 0	15	Error#
3	Parallel Data 1	16	Initialize#
4	Parallel Data 2	17	Select Input#
5	Parallel Data 3	18	GND
6	Parallel Data 4	19	GND
7	Parallel Data 5	20	GND
8	Parallel Data 6	21	GND
9	Parallel Data 7	22	GND
10	Acknowledge#	23	GND
11	Busy	24	GND
12	Paper empty	25	GND
13	Select	26	NC

● **SIO Connector (CN6)**

A . Connector size: 2 X 20 = 40 Pin ,2.0 mm, 180° ,BOX Header

B . Connector location

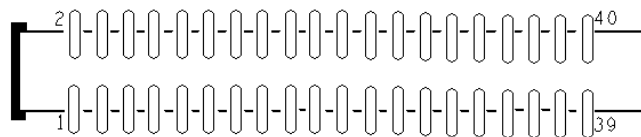

C . Connector pin definition

Pin	Definition	Pin	Definition
1	DCD1	21	DCD3
2	DSR1	22	DSR3
3	RXD1	23	RXD3

4	RTS1	24	RTS3
5	TXD1	25	TXD3
6	CTS1	26	CTS3
7	DTR1	27	DTR3
8	RI1	28	RI3
9	GND	29	GND
10	NC	30	NC
11	DCD2	31	DCD4
12	DSR2	32	DSR4
13	RXD2	33	RXD4
14	RTS2	34	RTS4
15	TXD2	35	TXD4
16	CTS2	36	CTS4
17	DTR2	37	DTR4
18	RI2	38	RI4
19	GND	39	GND
20	NC	40	NC

● **CPU FAN Connector(CN4)**

A . Connector size : 1 X 4 = 4 Pin , 2.54mm ,180° , FAN Connector

B . Connector location

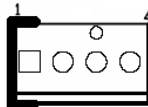

C . Connector pin definition

Pin	Definition	Pin	Definition
1	GND	3	Sense
2	+12V	4	NC

● **SYSTEM FAN1/FAN2 Connector(J1 , J5)**

A . Connector size : 1 X 3 = 3 Pin , 2.54mm ,180° , FAN Connector

B . Connector location



C . Connector pin definition

Pin	Definition	Pin	Definition
1	GND	3	Sense
2	+12V		

- **USB 2.0 , 0/1/4/5 Connector (J4 , J6)**

A . Connector size : 1 X 6 = 6 Pin , 2.0mm ,180° , JST Connector

B . Connector location

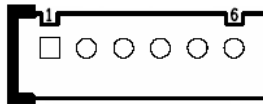

C .Connector pin definition

Pin	Definition	Pin	Definition
1	+5VSB	4	Data 1-/Data 5-
2	Data 0-/Data 4-	5	Data 1+/Data 5+
3	Data 0+/Data 4+	6	GND

- **USB 2.0 , 2/3 Connector (CN9)**

A . Connector size : 1 X 6 = 6 Pin , 15.2x16.8x17mm, 90° , FEMALE

B . Connector location

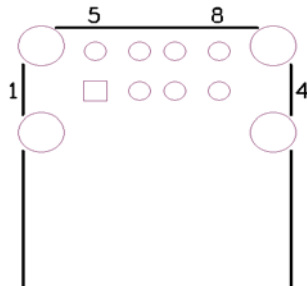

C .Connector pin definition

Pin	Definition	Pin	Definition
1	+5VSB	5	+5VSB
2	Data 2-	6	Data 3-
3	Data 2+	7	Data 3+
4	GND	8	GND

- **IDE Connector Primary (CN8)**

A . Connector size : 2 x 22 = 44pins,2.0mm, 180°,BOX Header

B . Connector location



C. Connector pin definition

Pin	Definition	Pin	Definition
1	Reset#	23	IOW#
2	GND	24	GND
3	Data 7	25	IOR#
4	Data 8	26	GND
5	Data 6	27	IOCHRDY
6	Data 9	28	GND
7	Data 5	29	DMA ACK#
8	Data 10	30	GND
9	Data 4	31	Interrupt
10	Data 11	32	NC
11	Data 3	33	DiskAddress 1
12	Data 12	34	DMA66 Detect
13	Data 2	35	DiskAddress 0
14	Data 13	36	DiskAddress 2
15	Data 1	37	HDCCS1#
16	Data 14	38	HDCCS3#
17	Data 0	39	HDD Active #
18	Data 15	40	GND
19	GND	41	+5V
20	NC	42	+5V
21	DMA REQ	43	GND
22	GND	44	GND

- **Compact Flash Connector (CN7)**

A . Connector size : Compact Flash Socket 50 Pin Connector

B . Connector location

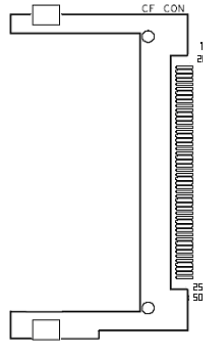

C . Connector pin definition

Pin	Definition	Pin	Definition
1	GND	26	GND
2	Data 3	27	Data 11
3	Data 4	28	Data 12
4	Data 5	29	Data 13
5	Data 6	30	Data 14
6	Data 7	31	Data 15
7	HDCCS1#	32	HDCCS3#
8	GND	33	N/C
9	GND	34	IOR#
10	GND	35	IOW#
11	GND	36	+5V
12	GND	37	Interrupt
13	+5V	38	+5V
14	GND	39	CF_CSEL#
15	GND	40	NC
16	GND	41	Reset#
17	GND	42	IOCHRDY
18	Disk Address 2	43	DMA REQ
19	Disk Address 1	44	DMA ACK#
20	Disk Address 0	45	HDD Active#
21	Data 0	46	DMA66 Dectec
22	Data 1	47	Data 8

23	Data 2	48	Data 9
24	NC	49	Data 10
25	GND	50	GND

- **GPIO (J10)**

A . Connector size : 2X5 = 10 PIN , 2.0mm , 180° , PIN Header

B . Connector location

C . Connector pin definition

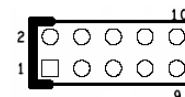

Pin	Definition	Pin	Definition
1	+5V	6	GP25_D_OUT1(PIN22)
2	GND	7	GP22_D_IN2(PIN25)
3	GP20_D_IN0(PIN27)	8	GP26_D_OUT2(PIN21)
4	GP24_D_OUT0(PIN23)	9	GP23_D_IN3(PIN24)
5	GP21_D_IN1(PIN26)	10	GP27_D_OUT3(PIN20)

*Digital I/O Used Port 801

Output		Input	
O0	GP24_D_OUT0(PIN23)	I0	GP20_D_IN0(PIN27)
O1	GP25_D_OUT1(PIN22)	I1	GP21_D_IN1(PIN26)
O2	GP26_D_OUT2(PIN21)	I2	GP22_D_IN2(PIN25)
O3	GP27_D_OUT3(PIN20)	I3	GP23_D_IN3(PIN24)

- **Disk On Module External Power (J11)**

A . Connector size : 1X2 = 2 PIN , 2.5mm , 180° , JST Connector

B . Connector location

C . Connector pin definition

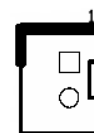

Pin	Definition	Pin	Definition
1	+5V	2	GND

- **82573L LAN1 / LAN2 LINK 100LED(JP15 /JP21)**

A . Connector size : 1X2 = 2 PIN , 2.54mm , 180° , PIN Header

B . Connector location

C . Connector pin definition



Pin	Definition	Pin	Definition
1	+3VSB	2	Speed100#

- **82573L LAN1 /LAN2 LINK 1000LED (JP17/JP19)**

A . Connector size : 1X2 = 2 PIN , 2.54mm , 180° , PIN Header

B . Connector location



C .Connector pin definition

Pin	Definition	Pin	Definition
1	+3VSB	2	Speed1000#

- **82573L LAN1 / LAN2 Activity LED (JP16/JP18)**

A . Connector size : 1X2 = 2 PIN , 2.54mm , 180° , PIN Header

B . Connector location



C .Connector pin definition

Pin	Definition	Pin	Definition
1	+3VSB	2	Activity#

- **IR (JP7)**

A . Connector size : 1X5 = 5 PIN , 2.54mm , 180° , PIN Header

B . Connector location

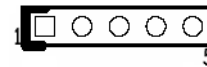

C .Connector pin definition

Pin	Definition	Pin	Definition
1	+5V	4	GND
2	CIRRX	5	IRTX
3	IRRX		

- **System Thermal Connector(J3 , J7)**

A . Connector size : 1X2 = 2 PIN , 2.54mm , 180° , PIN Header

B . Connector location



C .Connector pin definition

Pin	Definition	Pin	Definition
1	Thermal Pin	2	Thermal GND

- **Key board + mouse Connector(KM1)**

A . Connector size : MINI DIN 6 Pin Connector

B . Connector location

C .Connector pin definition

Pin	Definition	Pin	Definition
1	Keyboard Data	5	+5VSB
2	Mouse Data	6	Keyboard Clock
3	GND	7	NC
4	NC	8	Mouse Clock

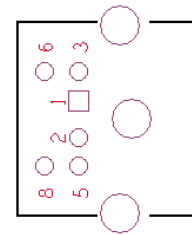

- **82573L LAN1 / LAN2 Connector (CN10 , CN11)**

A . Connector size : RJ45 LAN Connector

B . Connector location

C .Connector pin definition

Pin	Definition	Pin	Definition
1	MDI0P	7	MDI3P
2	MDI0N	8	MDI3N
3	MDI1P	9	ACTIVITY#
4	MDI2P	10	+5VSB
5	MDI2N	11	LINK100#
6	MDI1N	12	LINK1000#

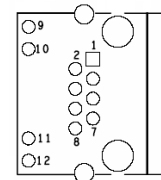

- **VGA Connector(VGA1)**

A . Connector size : VGA D-SUB 15 Pin Connector

B . Connector location

C .Connector pin definition

Pin	Definition	Pin	Definition
1	Red	9	+5V
2	Green	10	GND
3	Blue	11	NC
4	NC	12	DDC Data
5	GND	13	HSYNC
6	GND	14	VSYNC
7	GND	15	DDC Clock
8	GND		

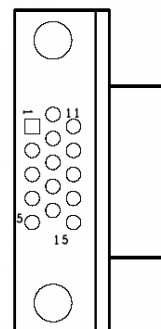

- **RTC Clear (JP6)**

A . Connector size : 1X3 = 3 PIN , 2.54mm , 180° , PIN Header

B . Connector location

C . Connector pin definition

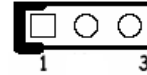

	Normal	Clear CMOS
JP9	*1-2	2-3

* = DEFAULT SET

- **(21) CF Card Master/Slave Select (JP14)**

A . Connector size : 1 X 3 = 3 PIN , 2.54mm , 180° , PIN Header

B . Connector location

C . Connector pin definition



	Master	Slave
J13	*1-2	2-3

* = DEFAULT SET

- **CCFL Connector(J2)**

A . Connector size : 1 X 7 = 7 PIN , 2.5mm JST Connector.

B . Connector location

C . Connector pin definition

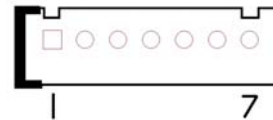

Pin	Definition	Pin	Definition
1	+5V	5	GND
2	+12V	6	GND
3	+12V	7	Backlight Enable
4	Backlight control	8	

- **Panel Voltage Select (JP1)**

A . Connector size : 1 X 3 = 3 PIN , 2.54mm , 180° , PIN Header

B . Connector location

C . Connector pin definition



PIN	1-2	*2-3
Def.	+5V	+3.3V

* = DEFAULT SET

- **Line_in Connector (JP13)**

A . Connector size : 1X4 = 4 PIN , 2.54mm , 180° , PIN Header

B . Connector location

C .Connector pin definition

Pin	Definition	Pin	Definition
1	LINE-IN-L	3	DETECT
2	GND	4	LINE-IN-R



- **HDD LED (JP20)**

A . Connector size : 1X2 = 2 PIN , 2.54mm , 180° , PIN Header

B . Connector location

C . Connector pin definition

Pin	Definition	Pin	Definition
1	+5V	2	HDD_ACTIVE#



- **SMBUS Connector(JP12)**

A . Connector size : 1X2 = 2 PIN , 2.54mm , 180° , PIN Header

B . Connector location

C . Connector pin definition

Pin	Definition	Pin	Definition
1	SMB_CLK	2	SMB_DATA



- **RESET Connector (JP11)**

A . Connector size : 1X2 = 2 PIN , 2.54mm , 180° , PIN Header

B . Connector location

C . Connector pin definition

Pin	Definition	Pin	Definition
1	GND	2	RESET#



- **POWER LED (JP8)**

A . Connector size : 1X2 = 2 PIN , 2.54mm , 180° , PIN Header

B . Connector location

C . Connector pin definition

Pin	Definition	Pin	Definition
1	PULL UP TO +5V	2	GND



- **PUSH BOTTON Connector (JP5)**

A . Connector size : 1X2 = 2 PIN , 2.54mm , 180° , PIN Header

B . Connector location

C . Connector pin definition

Pin	Definition	Pin	Definition
1	PWRBT	2	GND



- **COM4 RS232 RI# Pin Power Select & RI# Pin Select(JP4)**

A . Connector size : 1X5 = 5 PIN , 2.54mm , 180° , PIN Header

B . Connector location

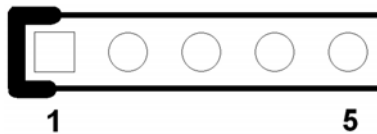

C . Connector pin definition

Pin	Definition	Pin	Definition
1	+5V	4	RI4#_SELECT
2	RI4#_SELECT	5	RI4#
3	+12V		

- **AT/ATX power mode select (JP3)**

A . Connector size : 1X2 = 2 PIN , 2.54mm , 180° , PIN Header

B . Connector location

C . Connector pin definition

Pin	Definition	Pin	Definition
1	PSO#	2	GND



- **POWER Connector (CON1)**

A . Connector size : 2X5 = 10PIN , 4.2mm , FEMALE

B . Connector location

C . Connector pin definition

Pin	Definition	Pin	Definition
1	PSO#	6	+5VSB
2	GND	7	+5V
3	GND	8	+5V
4	+12V	9	-12V
5	NC	10	GND

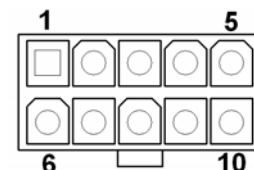

- **ATX AUX POWER Connector (CON2)**

A . Connector size : 2X2 = 2 PIN , 3.5mm , FEMALE r

B . Connector location

C . Connector pin definition

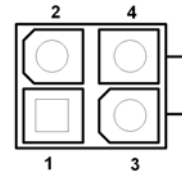

Pin	Definition	Pin	Definition
1	GND	3	+12V
2	GND	4	+12V

- **LVDS Connector (CN2, CN3)**

CN2

Pin No.	Description	Pin No.	Description
1	L_DDC_CLK	2	L_DDC_DATA
3	PANEL1_VDD	4	LB_DATAP0
5	NC	6	LB_DATAN0
7	NC	8	PANEL1_VDD
9	GND	10	LB_DATAP1
11	LB_CLKP	12	LB_DATAN1
13	LB_CLKN	14	GND
15	GND	16	PANEL1_BACKLIGHT
17	LB_DATAP2	18	PANEL1_BACKLIGHT
19	LB_DATAN2	20	GND

CN3

Pin No.	Description	Pin No.	Description
1	L_DDC_CLK	2	L_DDC_DATA
3	PANEL1_VDD	4	LA_DATAP0
5	NC	6	LA_DATAN0
7	NC	8	PANEL1_VDD
9	GND	10	LA_DATAP1
11	LA_CLKP	12	LA_DATAN1
13	LA_CLKN	14	GND
15	GND	16	PANEL1_BACKLIGHT
17	LA_DATAP2	18	PANEL1_BACKLIGHT
19	LA_DATAN2	20	GND

- **PCI SLOT (CN5)**

PIN	Side B	Side A	PIN	Side B	Side A
1	-12V	TRST#	2	TCK	+12V
3	GND	TMS	4	NC	TDI
5	+5V	+5V	6	+5V	INTA#

7	INTB#	INTC#	8	INTD#	+5V
9	NC	CLKRUN#	10	REQ1#	+5V
11	NC	GNT1#	12	GND	GND
13	GND	GND	14	CLK1	+3.3V STANDBY
15	GND	PCI_RST#	16	CLK0	+5V
17	GND	GNT0#	18	REQ0#	GND
19	+5V	PME#	20	AD31	AD30
21	AD29	+3.3V	22	GND	AD28
23	AD27	AD26	24	AD25	GND
25	+3.3V	AD24	26	C/BE#3	IDSEL_AD26
27	AD23	+3.3V	28	GND	AD22
29	AD21	AD20	30	AD19	GND
31	+3.3V	AD18	32	AD17	AD16
33	C/BE#2	+3.3V	34	GND	FRAME#
35	IRDY#	GND	36	+3.3V	TRDY#
37	DEVSEL#	GND	38	GND	STOP#
39	LOCK#	+3.3V	40	PERR#	RSV
41	+3.3V	RSV	42	SERR#	GND
43	+3.3V	PAR	44	C/BE#1	AD15
45	AD14	+3.3V	46	GND	AD13
47	AD12	AD11	48	AD10	GND
49	GND	AD9	50	KEYWAY	KEYWAY
51	KEYWAY	KEYWAY	52	AD8	C/BE#0
53	AD7	+3.3V	54	+3.3V	AD6
55	AD5	AD4	56	AD3	GND
57	GND	AD2	58	AD1	AD0
59	+5V	+5V	60	RSV	RSV
61	+5V	+5V	62	+5V	+5V

PCI Device interrupt and BUS Assignments

Chipset	Configuration BUS/DEVIC/FUNCTION	PCI INT#	REQ# /GNT#	Special feature description
PCI Slot1	1 / 17 / 0	A,B,C,D	0,1	
	1 / 18 / 0	D,A,B,C		

Chapter 3

Expansion

3.1 System Memory

EBC 500 incorporates Intel 945GM chipset supports up to 4GB un-buffered non-ECC DDR2 533/667 SDRAM.

3.2 Installing DIMM

To install DIMM

1. Make sure the two handles of the DIMM sockets are in the “open” position, i.e. the handles stay outward.

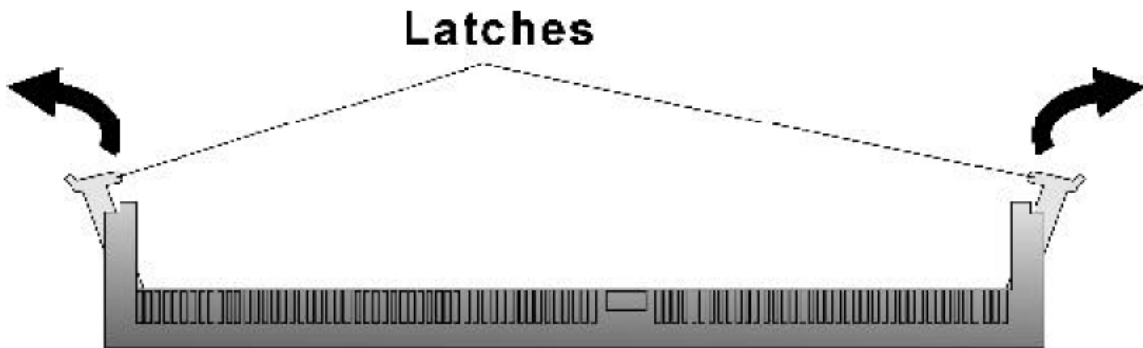

Figure3-1: How to Install DIMM (1)

2. Slowly slide the DIMM modules along the plastic guides in the both ends of the socket.

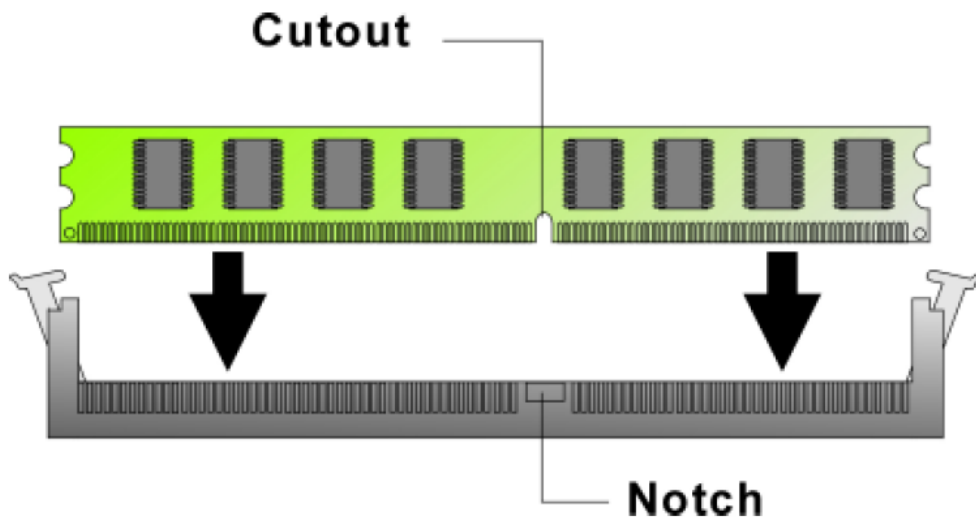

Figure 3-2: How to Install DIMM (2)

3. Then press the DIMM module down right into the socket, until a click is heard. That means the two handles automatically locked the memory modules into the right position of the DIMM socket.

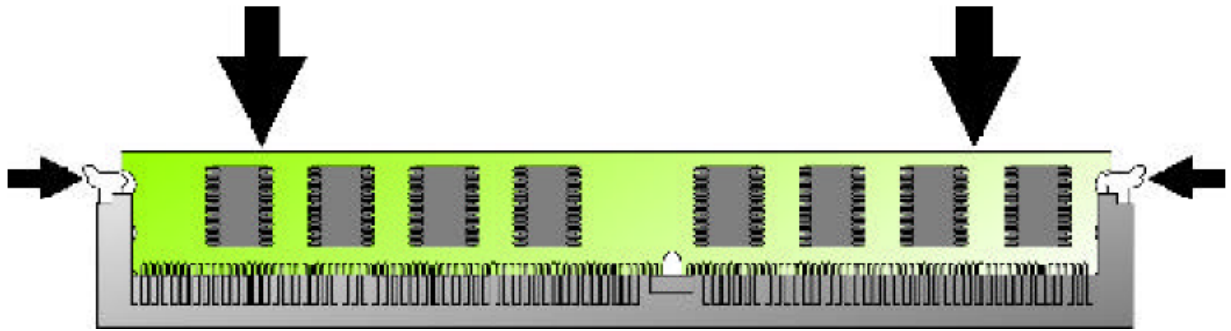

Figure 3-3: How to Install DIMM (3)

4. To take away the memory module, just push the both handles outward, the memory module will be ejected by the mechanism in the socket.

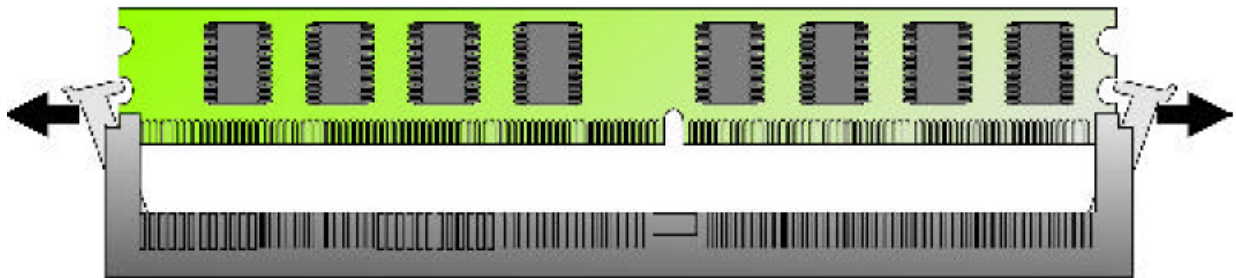

Figure 3-4: How to Install DIMM (4)

3.3 Installing Compact Flash

1. To install a Compact Flash memory card into EBC 500, align the notches on the card with the Compact Flash socket in the EBC 500. Then firmly insert the card into the socket until it is completely seated.

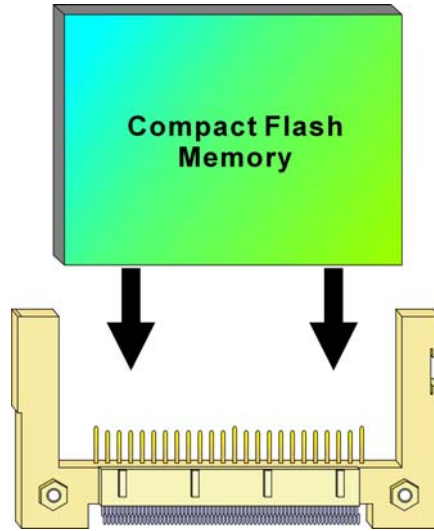

Figure 3-5: How to Install Compact Flash (1)

2. To remove the Compact Flash memory card from EBC 500, pull out the memory card from the Compact Flash socket.

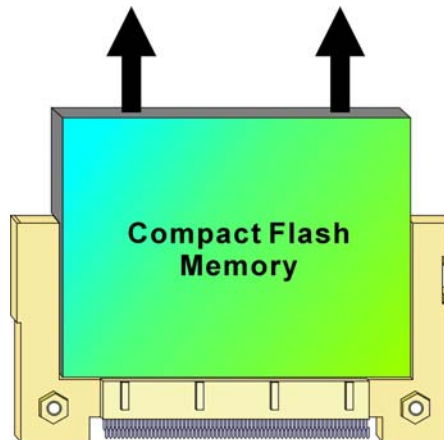

Figure 3-6: How to Uninstall Compact Flash (2)