

## **GENE-QM87**

Intel® 4<sup>th</sup> Generation Core™ i Series  
Processor

2 Gigabit Ethernet

2 USB3.0, 6 USB 2.0, 4 COM

8-bit Digital I/O

2 SATA 6.0Gb/s (Optional RAID)

1 CFast™, 1 Mini Card, LPC

## Copyright Notice

This document is copyrighted, 2015. All rights are reserved. The original manufacturer reserves the right to make improvements to the products described in this manual at any time without notice.

No part of this manual may be reproduced, copied, translated, or transmitted in any form or by any means without the prior written permission of the original manufacturer. Information provided in this manual is intended to be accurate and reliable. However, the original manufacturer assumes no responsibility for its use, or for any infringements upon the rights of third parties that may result from its use.

We reserve the right to make changes in the product design without notice to its users.

## Acknowledgments

All other products' name or trademarks are properties of their respective owners.

- AMI is a trademark of American Megatrends Inc.
- CFast™ is a trademark of the Compact Flash Association.
- Intel® and Core™ are trademarks of Intel® Corporation.
- Microsoft Windows® is a registered trademark of Microsoft Corp.
- ITE is a trademark of Integrated Technology Express, Inc.
- IBM, PC/AT, PS/2, and VGA are trademarks of International Business Machines Corporation.
- SoundBlaster is a trademark of Creative Labs, Inc.

**Please be notified that all other products' name or trademarks not be mentioned above are properties of their respective owners.**

## Packing List

Before you begin installing your card, please make sure that the following materials have been shipped:

- 1 DVD-ROM for Manual (in PDF Format) and Drivers
- 1 GENE-QM87
- 1 Power Cable 170204010R

If any of these items should be missing or damaged, please contact your distributor or sales representative immediately.

# Contents

## Chapter 1 General Information

1.1 Introduction.....	1-2
1.2 Features .....	1-3
1.3 Specifications .....	1-4

## Chapter 2 Quick Installation Guide

2.1 2.1 Safety Precautions .....	2-2
2.2 Location of Connectors and Jumpers .....	2-3
2.3 Mechanical Drawing .....	2-5
2.4 List of Jumpers .....	2-7
2.5 List of Connectors .....	2-8
2.6 Setting Jumpers .....	2-10
2.7 Mini-Card with mSATA / PCIe Selection (JP1) .....	2-11
2.8 Touch Screen 4/5/8-Wire Selection (JP2).....	2-11
2.9 LVDS Port 1 Backlight Inverter Voltage Selection (JP3) .....	2-11
2.10 LVDS Port 1 Backlight Lightness Control Mode Selection (JP4).....	2-12
2.11 LVDS Port 1 Operating Voltage Selection (JP5)...	2-12
2.12 LVDS Port 2 Operating Voltage Selection (JP6)...	2-12
2.13 LVDS Port 2 Backlight Inverter Voltage Selection (JP7) .....	2-13
2.14 LVDS Port 2 Backlight Lightness Control Mode Selection (JP8).....	13

2.15 AT/ATX Power Supply Mode Selection (JP9).....	2-13
2.16 Clear CMOS Jumper (JP10) .....	2-14
2.17 COM2 Pin8 Function Selection (JP11) .....	2-14
2.18 +5VSB Output w/SMBus (CN1) .....	2-14
2.19 LVDS Port 2 Inverter / Backlight Connector (CN2)	2-15
2.20 +5V Output for SATA HDD (CN3).....	2-16
2.21 External +5VSB Input (CN4) .....	2-16
2.22 CPU FAN (CN5) .....	2-16
2.23 SATA Port 2 (CN6).....	2-17
2.24 SATA Port 1 (CN7).....	2-17
2.25 Main Power Input (+12V ONLY) (CN8).....	2-18
2.26 Digital IO Port (CN9) .....	2-18
2.27 LVDS Port 1 Inverter / Backlight Connector (CN10) .....	2-19
2.28 SPI Programming Header (Debug ONLY) (CN11)	2-20
2.29 USB 2.0 Port 3 (CN12).....	2-20
2.30 USB 2.0 Port 4 (CN13).....	2-21
2.31 LVDS Port 1 Connector (CN14) .....	2-22
2.32 LVDS Port 2 Connector (CN15) .....	2-24
2.33 USB 2.0 Port 5 (CN16).....	2-26
2.34 USB 2.0 Port 6 (CN17).....	2-26
2.35 USB 2.0 Port 8 (CN18).....	2-27
2.36 USB 2.0 Port 7 (CN19).....	2-27
2.37 Touch Screen Connector (CN20).....	2-28
2.38 COM Port 4 (CN21).....	2-31

2.39 COM Port 3 (CN22).....	2-31
2.40 LPC Expansion Connector (CN23) .....	2-32
2.41 COM Port 2 (RS232/485/422) (CN24) .....	2-33
2.42 PS/2 Keyboard/Mouse Combo Port (CN25) .....	2-35
2.43 Stereo Audio RIGHT Channel (CN26) .....	2-36
2.44 Stereo Audio LEFT Channel (CN27).....	2-36
2.45 Front Panel (CN28) .....	2-37
2.46 10M/100M/1G Ethernet Port 1 (CN29).....	2-37
2.47 10M/100M/1G Ethernet Port 2 (CN30).....	2-38
2.48 USB 2.0/3.0 Port 1 & 2 (CN31) .....	2-39
2.49 High Definition Audio (CN32) .....	2-40
2.50 COM Port 1 (D-SUB 9) (CN33).....	2-41
2.51 HDMI (CN34).....	2-41
2.52 VGA / DVI Ports (depend on hardware configuration) (CN35).....	2-43
2.53 UIM Socket (CN36) .....	2-45
2.54 Mini-Card (PCIE1) .....	2-46
2.55 C-FAST (CFD1).....	2-49
2.56 DDR3L SO-DIMM Slot (DIMM1) .....	2-50

### **Chapter 3 AMI BIOS Setup**

3.1 System Test and Initialization. ....	3-2
3.2 AMI BIOS Setup .....	3-3

### **Chapter 4 Driver Installation**

4.1 Installation.....	4-3
-----------------------	-----

**Appendix A Programming The Watchdog Timer**

- A.1 Programming .....A-2
- A.2 F81866 Watchdog Timer Initial Program .....A-5

**Appendix B I/O Information**

- B.1 I/O Address Map .....B-2
- B.2 Memory Address Map .....B-4
- B.3 IRQ Mapping Chart .....B-5
- B.4 DMA Channel Assignments..... B-8

**Appendix C Mating Connector**

- C.1 List of Mating Connectors and Cables..... C-2

**Appendix D Electrical Specifications for I/O Ports**

- D.1 Electrical Specifications for I/O Ports ..... D-2

**Appendix E DIO**

- E.1 DIO List .....E-2

Chapter

1

**General  
Information**

## 1.1 Introduction

---

The GENE-QM87 supports Intel® 4<sup>th</sup> Generation Core™ i Series processors which when paired with the Intel® QM87 chipset offers a high performance computing platform with low power consumption. This new product supports 204-pin DDR3L SODIMM at speeds of 1333/1600 MHz, up to 8 GB.

One CFast™ and two SATA 6.0Gb/s (Optional RAID) interfaces provide ample storages. With dual Gigabit Ethernet, four COM ports, two USB3.0 and six USB2.0, the GENE-QM87 meets the requirements of today's demanding applications.

Display requirements are met with an abundance of interfaces such as CRT, HDMI, DVI-I and LCD. The graphic engine adopts Intel® QM87 to offer high definition display function. In addition, it supports up to triple view for two 24-bit Dual-Channel LVDS, one HDMI, one DVI and one CRT.

With all of its integrated features, the GENE-QM87 strikes a balance of performance and price. This versatile product targets Industrial Automation, Entertainment, KIOSK/POS, Transportation, Banking, and Digital Signage.

## 1.2 Features

---

- Intel® 4<sup>th</sup> Generation Core™ i5-4402E Processor
- Intel® QM87
- 204-pin DDR3L 1333/1600 MHz SODIMM x 1, Up to 8 GB
- Gigabit Ethernet x 2
- CRT, DVI, 18/24-bit Dual-Channel LVDS LCD x 2, HDMI x 1
- 2 CH Audio + 2W AMP
- SATA 6.0Gb/s x 2 (Optional RAID), CFast™ x 1
- USB3.0 x 2, USB2.0 x 6, COM x 4, 8-bit Digital I/O
- Mini Card x 1
- DC 12V; AT or ATX (supports external +5V stand-by power input)
- Supports iAMT with Intel® QM87
- Supports TPM
- Onboard 4/5/8-wire Resistive Touch Screen Controller

### 1.3 Specifications

---

#### System

- **From Factor** 3.5"
  - **Processor** Intel® 4<sup>th</sup> Generation Core™ i5-4402E Processors
  - **System Memory** 204-pin DDR3L 1333/1600 MHz SODIMM x 1, Max. 8GB
  - **Chipset** Intel® QM87 PCH
  - **Ethernet** Intel® I217 Gigabit PHY x1 & Intel® I211 Gigabit x 1, RJ-45 x 2
  - **BIOS** Plug & Play BIOS – 16MB flash
  - **Wake On LAN** Yes
  - **Watchdog Timer** Generates a time-out system reset
  - **H/W Status Monitoring** Supports power supply voltages and temperature monitoring
  - **Expansion Interface** Mini Card x 1 or mSATA (by jumper setting), SM bus, LPC interface/Sim Card Socket
  - **Trusted Platform Module** V1.2, Infineon SLB9635TT1.2
  - **Battery** Lithium Battery
  - **Power Requirement** +12V, AT/ATX
  - **Board Size** 5.75" x 4" (146mm x 101.6mm)
  - **Gross Weight** 0.88 lb (0.4Kg)
  - **Operating Temperature** 32°F~140°F (0°C~60°C)
  - **Storage Temperature** -40°F~176°F (-40°C~80°C)
-

- **Operating Humidity** 0% ~ 90% relative humidity, non-condensing

**Display: Supports CRT/LCD, HDMI/LCD simultaneous / tripple view displays**

- **Chipset** Intel® QM87 integrated
- **Memory** Shared system memory up to 512MB
- **Resolution** Up to 2048x1536 for CRT  
Up to 1920 x 1200 for LCD, HDMI, DVI
- **HDMI** HDMI x 1
- **DVI** DVI x 1

**I/O:**

- **Storage** SATA 6.0Gb/s x 2 , CFast™ x 1
- **Serial Port** RS-232 x 3;  
RS-232/422/485 (auto flow) x 1
- **USB** USB3.0 x 2, USB2.0 x 6
- **PS/2 Port** Keyboard x 1, Mouse x 1
- **Digital I/O** 8-bit Programmable
- **Audio** Line-in, Line-out, Mic-in

**Note:** If the SATA storage (CFast/ mSATA/ SSD) cannot be detected by BIOS and resulted in “SYNC fail,” it is because of the compatibility issue with 4<sup>th</sup> generation Intel® Core™ i Series processor. Please contact with the storage supplier for getting the SATA compatible list for 4<sup>th</sup> generation Intel® Core™ i Series processor, or contact with AAEON sales to get Approval Vender List of SATA storage.

Chapter

2

**Quick  
Installation  
Guide**

## 2.1 Safety Precautions

---

**Warning!**

*Always completely disconnect the power cord from your board whenever you are working on it. Do not make connections while the power is on, because a sudden rush of power can damage sensitive electronic components.*

**Caution!**

*Always ground yourself to remove any static charge before touching the board. Modern electronic devices are very sensitive to static electric charges. Use a grounding wrist strap at all times. Place all electronic components on a static-dissipative surface or in a static-shielded bag when they are not in the chassis*

## 2.2 Location of Connectors and Jumpers

### Component Side

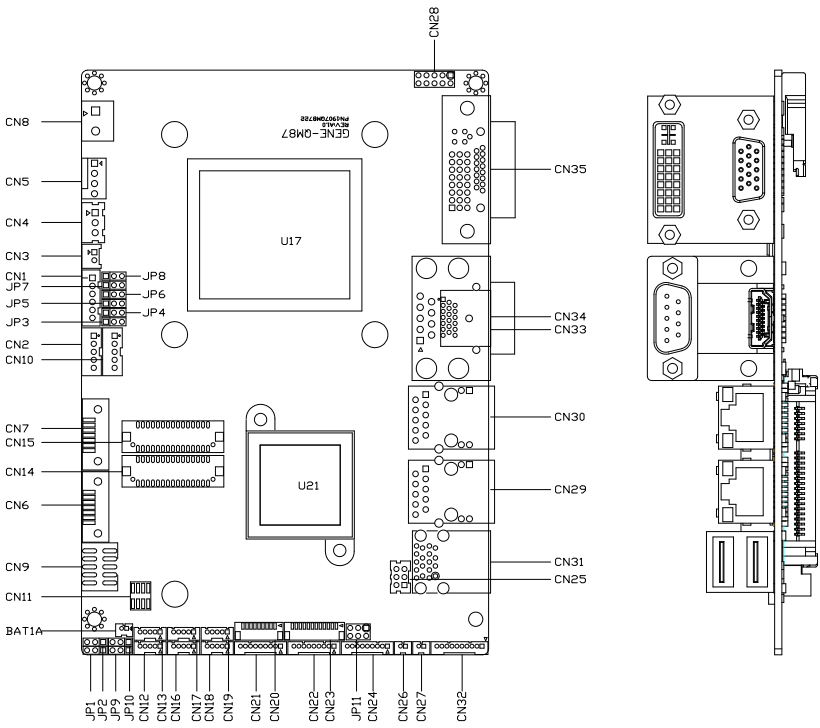

Solder Side

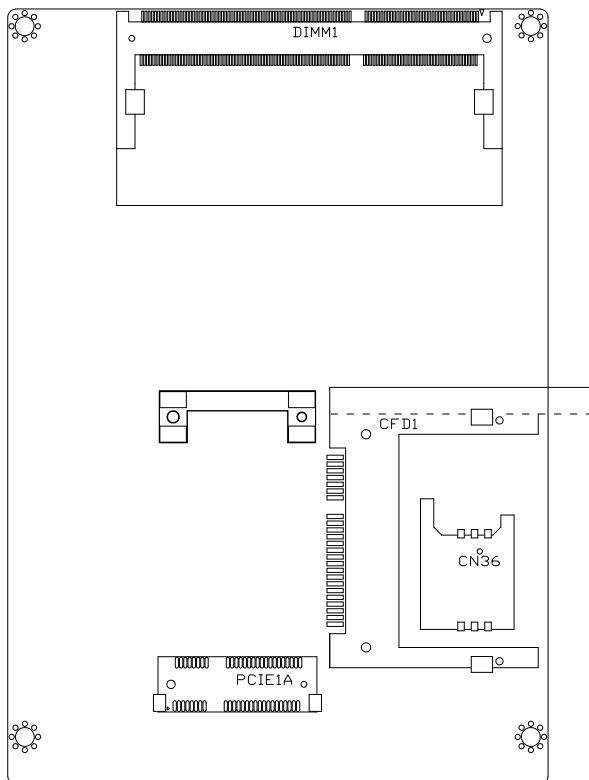

### 2.3 Mechanical Drawing

#### Component Side

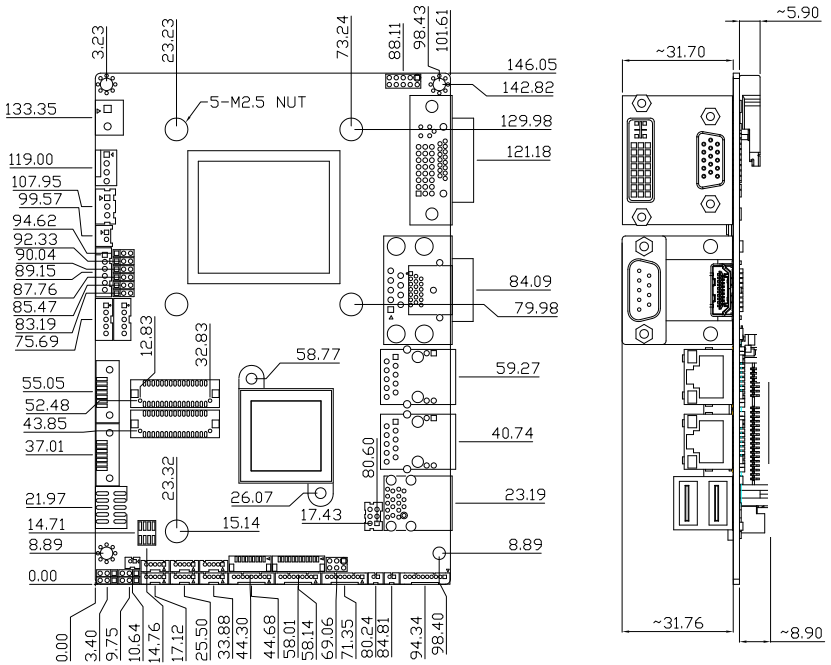

Solder Side

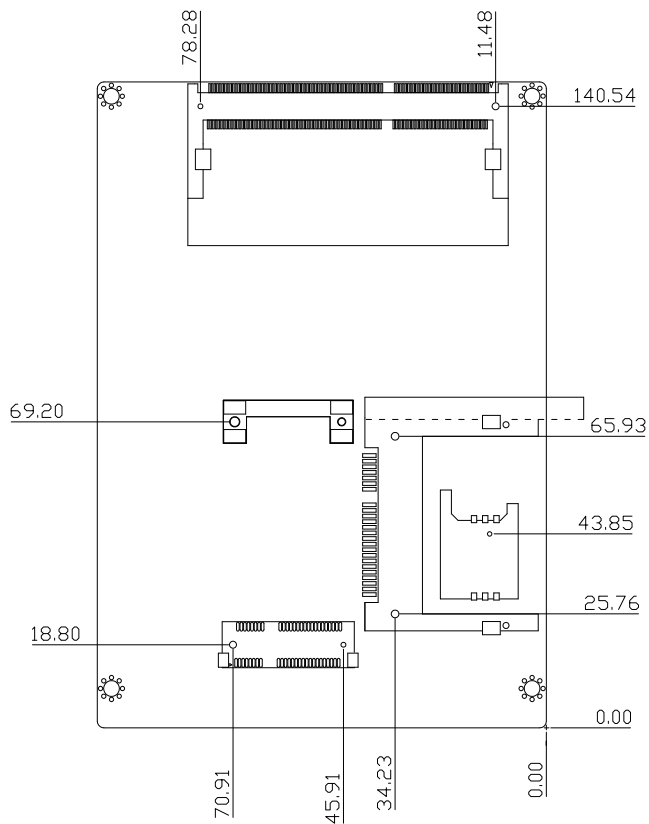

## 2.4 List of Jumpers

---

The board has a number of jumpers that allow you to configure your system to suit your application.

The table below shows the function of each of the board's jumpers:

Label	Function
JP1	mini-Card with mSATA / PCIe Selection
JP2	Touch Screen 4/5/8-wire Mode Selection
JP3	LVDS Port 1 Backlight Inverter Voltage Selection
JP4	LVDS Port 1 Backlight Lightness Control Mode Selection
JP5	LVDS Port 1 Operating Voltage Selection
JP6	LVDS Port 2 Operating Voltage Selection
JP7	LVDS Port 2 Backlight Inverter Voltage Selection
JP8	LVDS Port 2 Backlight Lightness Control Mode Selection
JP9	AT/ATX Power Supply Mode Selection
JP10	Clear CMOS Jumper
JP11	COM2 Pin8 Function Selection

## 2.5 List of Connectors

---

The board has a number of connectors that allow you to configure your system to suit your application. The table below shows the function of each board's connectors:

Label	Function
CN1	+5VSB Output w/SMBus
CN2	LVDS Port 2 Inverter / Backlight Connector
CN3	+5V Output for SATA HDD
CN4	External +5VSB Input
CN5	CPU FAN
CN6	SATA Port 2
CN7	SATA Port1
CN8	Main Power Input (+12V ONLY)
CN9	Digital IO Port
CN10	LVDS Port 1 Inverter / Backlight Connector
CN11	SPI Programming Header (Debug ONLY)
CN12	USB 2.0 Port 3
CN13	USB 2.0 Port 4
CN14	LVDS Port 1
CN15	LVDS Port 2
CN16	USB 2.0 Port 5
CN17	USB 2.0 Port 6
CN18	USB 2.0 Port 8
CN19	USB 2.0 Port 7

CN20	Touch Screen Connector
CN21	COM Port 4
CN22	COM Port 3
CN23	LPC Expansion Connector
CN24	COM Port 2 (RS232/485/422)
CN25	PS/2 Keyboard/Mouse Combo Port
CN26	Stereo Audio RIGHT Channel
CN27	Stereo Audio LEFT Channel
CN28	Front Panel
CN29	10M/100M/1G Ethernet Port 1
CN30	10M/100M/1G Ethernet Port 2
CN31	USB 2.0/3.0 Port 1 & 2
CN32	High Definition Audio
CN33	COM Port 1
CN34	HDMI
CN35	VGA / DVI Ports (depend on hardware configuration)
CN36	UIM Socket
PCIE1	mini-Card
CFD1	C-FAST
DIMM1	DDR3L SODIMM

## 2.6 Setting Jumpers

---

You configure your card to match the needs of your application by setting jumpers. A jumper is the simplest kind of electric switch. It consists of two metal pins and a small metal clip (often protected by a plastic cover) that slides over the pins to connect them. To “close” a jumper you connect the pins with the clip.

To “open” a jumper you remove the clip. Sometimes a jumper will have three pins, labeled 1, 2 and 3. In this case you would connect either pins 1 and 2 or 2 and 3.

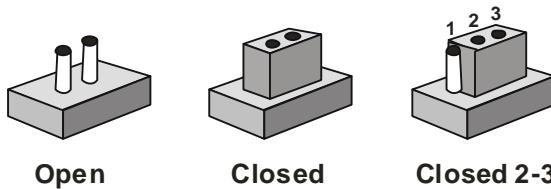

A pair of needle-nose pliers may be helpful when working with jumpers.

If you have any doubts about the best hardware configuration for your application, contact your local distributor or sales representative before you make any change.

Generally, you simply need a standard cable to make most connections.

## 2.7 Mini-Card with mSATA / PCIe Selection (JP1)



mSATA



PCIe (Default)

JP1	Function
1-2	mSATA
2-3	PCIe (Default)

## 2.8 Touch Screen 4/5/8-Wire Selection (JP2)



4/8-wire mode (Default)



5-wire mode

JP2	Function
1-2	4/8-wire mode (Default)
2-3	5-wire mode

## 2.9 LVDS Port 1 Backlight Inverter Voltage Selection (JP3)



+12V



+5V

JP3	Function
1-2	+12V
2-3	+5V (Default)

## 2.10 LVDS Port 1 Backlight Lightness Control Mode Selection (JP4)

---



VR Mode



PWM Mode (Default)

JP4	Function
1-2	VR Mode
2-3	PWM Mode (Default)

## 2.11 LVDS Port 1 Operating Voltage Selection (JP5)

---



+5V



+3.3V (Default)

JP5	Function
1-2	+5V
2-3	+3.3V (Default)

## 2.12 LVDS Port 2 Operating Voltage Selection (JP6)

---



+5V



+3.3V (Default)

JP6	Function
1-2	+5V
2-3	+3.3V (Default)

### 2.13 LVDS Port 2 Backlight Inverter Voltage Selection (JP7)

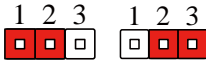

+12V

+5V (Default)

JP7	Function
1-2	+12V
2-3	+5V (Default)

### 2.14 LVDS Port 2 Backlight Lightness Control Mode Selection (JP8)



VR Mode

PWM Mode (Default)

JP8	Function
1-2	VR Mode
2-3	PWM Mode (Default)

### 2.15 AT/ATX Power Supply Mode Selection (JP9)



ATX Mode

AT Mode (Default)

JP8	Function
1-2	ATX Mode
2-3	AT Mode (Default)

## 2.16 Clear CMOS Jumper (JP10)



Normal (Default)



Clear CMOS

JP10	Function
1-2	Normal (Default)
2-3	Clear CMOS

## 2.17 COM2 Pin8 Function Selection (JP11)



+12V



Ring (Default)



+5V

JP11	Function
1-2	+12V
3-4	Ring (Default)
5-6	+5V

## 2.18 +5VSB Output w/SMBus (CN1)

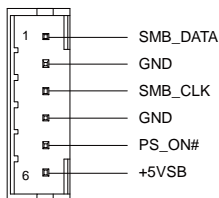

Pin	Pin Name	Signal Type	Signal Level
1	SMB_DATA	I/O	+3.3V
2	GND	GND	
3	SMB_CLK	I/O	+3.3V
4	GND	GND	
5	PS_ON#	OUT	+3.3V
6	+5VSB	PWR	+5V

## 2.19 LVDS Port 2 Inverter / Backlight Connector (CN2)

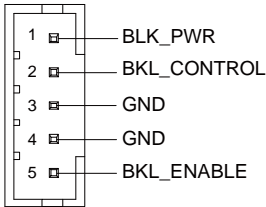

Pin	Pin Name	Signal Type	Signal Level
1	BKL_PWR	PWR	+5V / +12V
2	BKL_CONTROL	OUT	
3	GND	GND	
4	GND	GND	
5	BKL_ENABLE	OUT	+5V

**Note:** LVDS2/BKL\_PWR can be set to +5V or +12V by JP7.

LVDS2/BKL\_CONTROL can be set by JP8.

The driving current supports up to 2A.

## 2.20 +5V Output for SATA HDD (CN3)

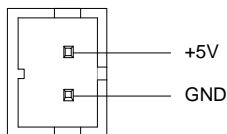

Pin	Pin Name	Signal Type	Signal Level
1	+5V	PWR	+5V
2	GND	GND	

## 2.21 External +5VSB Input (CN4)

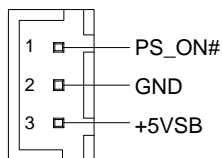

Pin	Pin Name	Signal Type	Signal Level
1	PS_ON#	OUT	+3.3V
2	GND	GND	
3	+5VSB	PWR	+5V

## 2.22 CPU FAN (CN5)

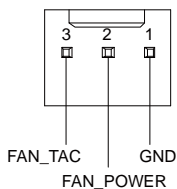

Pin	Pin Name	Signal Type	Signal Level
1	GND	GND	
2	FAN_POWER	PWR	+12V
3	FAN_TAC	IN	
4	FAN_CTL	IN	

### 2.23 SATA Port 2 (CN6)

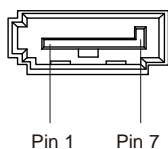

Pin	Pin Name	Signal Type	Signal Level
1	GND	GND	
2	SATA_TX1+	DIFF	
3	SATA_TX1-	DIFF	
4	GND	GND	
5	SATA_RX1-	DIFF	
6	SATA_RX1+	DIFF	
7	GND	GND	

### 2.24 SATA Port 1 (CN7)

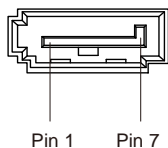

Pin	Pin Name	Signal Type	Signal Level
1	GND	GND	
2	SATA_TX0+	DIFF	
3	SATA_TX0-	DIFF	
4	GND	GND	
5	SATA_RX0-	DIFF	
6	SATA_RX0+	DIFF	
7	GND	GND	

## 2.25 Main Power Input (+12V ONLY) (CN8)

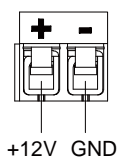

Pin	Pin Name	Signal Type	Signal Level
1	BKL_PWR	PWR	+5V / +12V
2	BKL_CONTROL	OUT	

## 2.26 Digital IO Port (CN9)

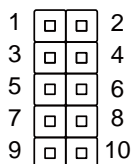

Pin	Pin Name	Signal Type	Signal Level
-----	----------	-------------	--------------

1	DIO0	I/O	+5V
2	DIO1	I/O	+5V
3	DIO2	I/O	+5V
4	DIO3	I/O	+5V
5	DIO4	I/O	+5V
6	DIO5	I/O	+5V
7	DIO6	I/O	+5V
8	DIO7	I/O	+5V
9	+5V	PWR	+5V
10	GND	GND	

## 2.27 LVDS Port 1 Inverter / Backlight Connector (CN10)

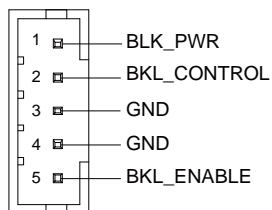

Pin	Pin Name	Signal Type	Signal Level
1	BKL_PWR	PWR	+5V / +12V
2	BKL_CONTROL	OUT	
3	GND	GND	
4	GND	GND	

---

5            BKL\_ENABLE            OUT            +5V

---

**Note:** LVDS2/BKL\_PWR can be set to +5V or +12V by JP3.

LVDS2/BKL\_CONTROL can be set by JP4.

The driving current supports up to 2A.

## 2.28 SPI Programming Header (Debug ONLY) (CN11)

---

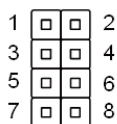

Pin	Pin Name	Signal Type	Signal Level
1	+3.3V	PWR	+3.3V
2	GND	GND	
3	CS#	I/O	
4	CLK	I/O	
5	SO	I/O	
6	SI	I/O	
7	NC		
8	NC		

---

## 2.29 USB 2.0 Port 3 (CN12)

---

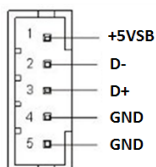

Pin	Pin Name	Signal Type	Signal Level
1	+5VSB	PWR	+5V
2	USB2_D-	DIFF	
3	USB2_D+	DIFF	
4	GND	GND	
5	GND	GND	

### 2.30 USB 2.0 Port 4 (CN13)

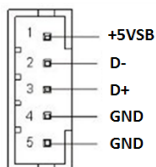

Pin	Pin Name	Signal Type	Signal Level
1	+5VSB	PWR	+5V
2	USB3_D-	DIFF	
3	USB3_D+	DIFF	
4	GND	GND	
5	GND	GND	

### 2.31 LVDS Port 1 Connector (CN14)

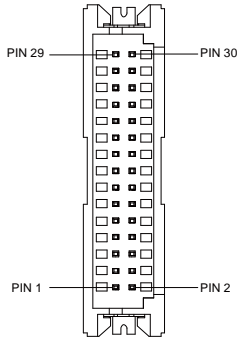

Pin	Pin Name	Signal Type	Signal Level
1	BKL_ENABLE	OUT	
2	BKL_CONTROL	OUT	
3	LCD_PWR	PWR	+3.3V/+5V
4	GND	GND	
5	LVDS_A_CLK-	DIFF	
6	LVDS_A_CLK+	DIFF	
7	LCD_PWR	PWR	+3.3V/+5V
8	GND	GND	
9	LVDS_DA0-	DIFF	
10	LVDS_DA0+	DIFF	
11	LVDS_DA1-	DIFF	

12	LVDS_DA1+	DIFF	
13	LVDS_DA2-	DIFF	
14	LVDS_DA2+	DIFF	
15	LVDS_DA3-	DIFF	
16	LVDS_DA3+	DIFF	
17	DDC_DATA	I/O	+3.3V
18	DDC_CLK	I/O	+3.3V
19	LVDS_DB0-	DIFF	
20	LVDS_DB0+	DIFF	
21	LVDS_DB1-	DIFF	
22	LVDS_DB1+	DIFF	
23	LVDS_DB2-	DIFF	
24	LVDS_DB2+	DIFF	
25	LVDS_DB3-	DIFF	
26	LVDS_DB3+	DIFF	
27	LCD_PWR	PWR	+3.3V/+5V
28	GND	GND	
29	LVDS_B_CLK-	DIFF	
30	LVDS_B_CLK+	DIFF	

**Note:** LVDS1 LCD\_PWR can be set to +3.3V or +5V by JP5.  
The max. driving current is 2A.

## 2.32 LVDS Port 2 Connector (CN15)

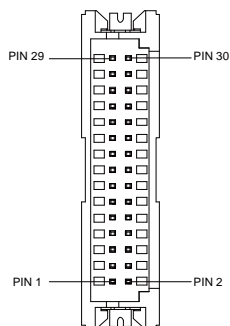

Pin	Pin Name	Signal Type	Signal Level
1	BKL_ENABLE	OUT	
2	BKL_CONTROL	OUT	
3	LCD_PWR	PWR	+3.3V/+5V
4	GND	GND	
5	LVDS_C_CLK-	DIFF	
6	LVDS_C_CLK+	DIFF	
7	LCD_PWR	PWR	+3.3V/+5V
8	GND	GND	
9	LVDS_DC0-	DIFF	
10	LVDS_DC0+	DIFF	
11	LVDS_DC1-	DIFF	

12	LVDS_DC1+	DIFF	
13	LVDS_DC2-	DIFF	
14	LVDS_DC2+	DIFF	
15	LVDS_DC3-	DIFF	
16	LVDS_DC3+	DIFF	
17	DDC_DATA	I/O	+3.3V
18	DDC_CLK	I/O	+3.3V
19	LVDS_DD0-	DIFF	
20	LVDS_DD0+	DIFF	
21	LVDS_DD1-	DIFF	
22	LVDS_DD1+	DIFF	
23	LVDS_DD2-	DIFF	
24	LVDS_DD2+	DIFF	
25	LVDS_DD3-	DIFF	
26	LVDS_DD3+	DIFF	
27	LCD_PWR	PWR	+3.3V/+5V
28	GND	GND	
29	LVDS_D_CLK-	DIFF	
30	LVDS_D_CLK+	DIFF	

**Note:** LVDS2 LCD\_PWR can be set to +3.3V or +5V by JP6.  
The max. driving current is 2A.

### 2.33 USB 2.0 Port 5 (CN16)

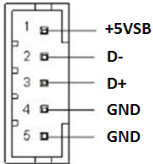

Pin	Pin Name	Signal Type	Signal Level
1	+5VSB	PWR	+5V
2	USB4_D-	DIFF	
3	USB4_D+	DIFF	
4	GND	GND	
5	GND	GND	

### 2.34 USB 2.0 Port 6 (CN17)

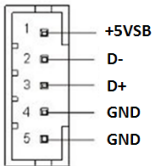

Pin	Pin Name	Signal Type	Signal Level
1	+5VSB	PWR	+5V
2	USB5_D-	DIFF	
3	USB5_D+	DIFF	
4	GND	GND	
5	GND	GND	

### 2.35 USB 2.0 Port 8 (CN18)

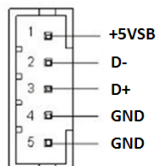

Pin	Pin Name	Signal Type	Signal Level
1	+5VSB	PWR	+5V
2	USB7_D-	DIFF	
3	USB7_D+	DIFF	
4	GND	GND	
5	GND	GND	

### 2.36 USB 2.0 Port 7 (CN19)

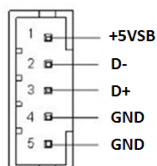

Pin	Pin Name	Signal Type	Signal Level
1	+5VSB	PWR	+5V
2	USB6_D-	DIFF	
3	USB6_D+	DIFF	
4	GND	GND	
5	GND	GND	

## 2.37 Touch Screen Connector (CN20)

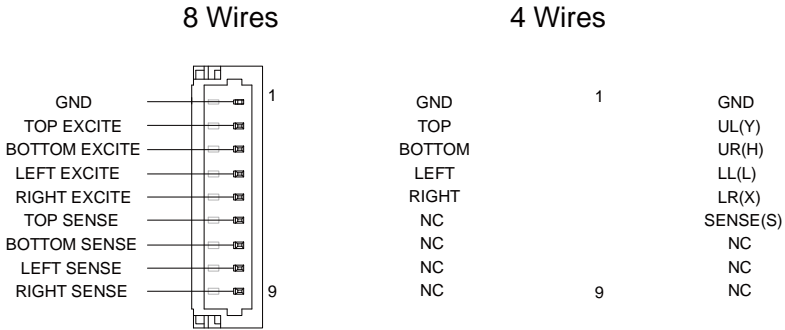

### 8 Wires

Pin	Pin Name	Signal Type	Signal Level
1	GND	GND	
2	TOP EXCITE	IN	
3	BOTTOM EXCITE	IN	
4	LEFT EXCITE	IN	
5	RIGHT EXCITE	IN	
6	TOP SENSE	IN	
7	BOTTOM SENSE	IN	
8	LEFT SENSE	IN	
9	RIGHT SENSE	IN	

4 Wires

5 Wires

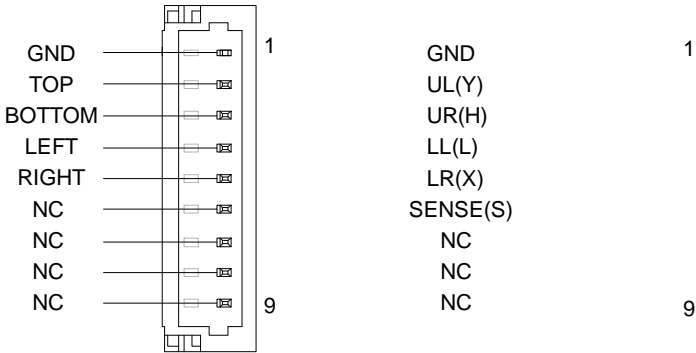

4 Wires

Pin	Pin Name	Signal Type	Signal Level
1	GND	GND	
2	TOP	IN	
3	BOTTOM	IN	
4	LEFT	IN	
5	RIGHT	IN	
6	NC		
7	NC		
8	NC		
9	NC		

Wires

## 5 Wires

1

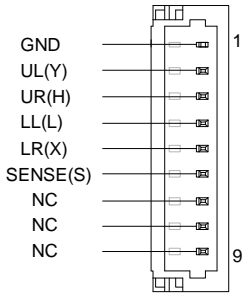

9

## 5 Wires

Pin	Pin Name	Signal Type	Signal Level
1	GND	GND	
2	UL(Y)	IN	
3	UR(H)	IN	
4	LL(L)	IN	
5	LR(X)	IN	
6	SENSE(S)	IN	
7	NC		
8	NC		
9	NC		

**Note:** Touch mode can be set by JP2.

### 2.38 COM Port 4 (CN21)

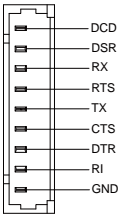

Pin	Pin Name	Signal Type	Signal Level
1	DCD	IN	
2	DSR	IN	
3	RX	IN	
4	RTS	OUT	±9V
5	TX	OUT	±9V
6	CTS	IN	
7	DTR	OUT	±9V
8	RI	IN	
9	GND	GND	

### 2.39 COM Port 3 (CN22)

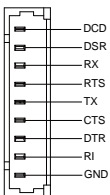

Pin	Pin Name	Signal Type	Signal Level
1	DCD	IN	
2	DSR	IN	
3	RX	IN	
4	RTS	OUT	±9V
5	TX	OUT	±9V
6	CTS	IN	
7	DTR	OUT	±9V
8	RI	IN	
9	GND	GND	

## 2.40 LPC Expansion Connector (CN23)

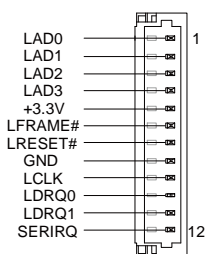

Pin	Pin Name	Signal Type	Signal Level
1	LAD0	I/O	+3.3V
2	LAD1	I/O	+3.3V
3	LAD2	I/O	+3.3V
4	LAD3	I/O	+3.3V

5	+3.3V	PWR	+3.3V
6	LFRAME#	IN	
7	LRESET#	OUT	+3.3V
8	GND	GND	
9	LCLK	OUT	
10	LDRQ0	IN	
11	LDRQ1 (EXT_SMI#)	IN	
12	SERIRQ	I/O	+3.3V

## 2.41 COM Port 2 (RS232/485/422) (CN24)

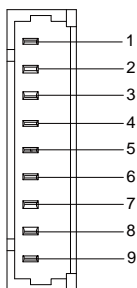

### RS232

Pin	Pin Name	Signal Type	Signal Level
1	DCD	IN	
2	DSR	IN	

3	RX	IN	
4	RTS	OUT	±6V
5	TX	OUT	±6V
6	CTS	IN	
7	DTR	OUT	±6V
8	RI/+5V/+12V	IN/ PWR	+5V/+12V
9	GND	GND	

**RS-422**

Pin	Pin Name	Signal Type	Signal Level
1	RS422_TX-	OUT	±5V
2	NC		
3	RS422_TX+	IN	
4	NC		
5	RS422_RX+	OUT	±5V
6	NC		
7	RS422_RX-	IN	
8	NC/+5V/+12V	PWR	+5V/+12V
9	GND	GND	

## RS-485

Pin	Pin Name	Signal Type	Signal Level
1	RS485_D-	I/O	±5V
2	NC		
3	RS485_D+	I/O	±5V
4	NC		
5	NC		
6	NC		
7	NC		
8	NC/+5V/+12V	PWR	+5V/+12V
9	GND	GND	

**Note:** COM2 RS-232/422/485 can be set by BIOS setting. Default is RS-232.  
Pin 8 function can be set by JP11.

## 2.42 PS/2 Keyboard/Mouse Combo Port (CN25)

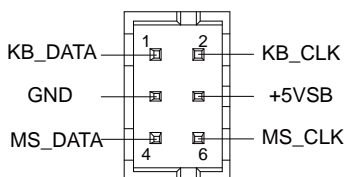

Pin	Pin Name	Signal Type	Signal Level
1	KB_DATA	I/O	+5V
2	KB_CLK	I/O	+5V
3	GND	GND	

4	+5VSB	PWR	+5V
5	MS_DATA	I/O	+5V
6	MS_CLK	I/O	+5V

### 2.43 Stereo Audio RIGHT Channel (CN26)

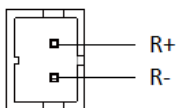

Pin	Pin Name	Signal Type	Signal Level
1	R+	OUT	
2	R-	OUT	

### 2.44 Stereo Audio LEFT Channel (CN27)

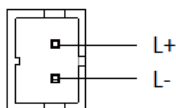

Pin	Pin Name	Signal Type	Signal Level
1	L+	OUT	
2	L-	OUT	

## 2.45 Front Panel (CN28)

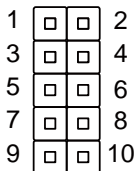

Pin	Pin Name	Pin	Pin Name
Pin 1	PWR_BTN-	Pin 2	PWR_BTN+
Pin 3	HDD_LED-	Pin 4	HDD_LED+
Pin 5	SPEAKER-	Pin 6	SPEAKER+
Pin 7	PWR_LED-	Pin 8	PWR_LED+
Pin 9	H/W RESET-	Pin 10	H/W RESET+

## 2.46 10M/100M/1G Ethernet Port 1 (CN29)

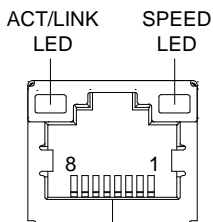

Pin	Pin Name	Signal Type	Signal Level
1	MDI0+	DIFF	
2	MDI0-	DIFF	
3	MDI1+	DIFF	
4	MDI2+	DIFF	

5	MDI2-	DIFF
6	MDI1-	DIFF
7	MDI3+	DIFF
8	MDI3-	DIFF

**Note:** The Intel/Clarkvillie (PHY) provides a standard IEEE 802.3 Ethernet interface for 1000BASE-T, 100BASE-TX, and 10BASE-T applications.

## 2.47 10M/100M/1G Ethernet Port 2 (CN30)

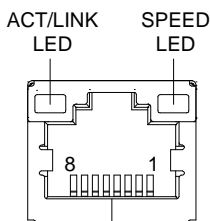

Pin	Pin Name	Signal Type	Signal Level
1	MDI0+	DIFF	
2	MDI0-	DIFF	
3	MDI1+	DIFF	
4	MDI2+	DIFF	
5	MDI2-	DIFF	
6	MDI1-	DIFF	
7	MDI3+	DIFF	
8	MDI3-	DIFF	

## 2.48 USB 2.0/3.0 Port 1 &amp; 2 (CN31)

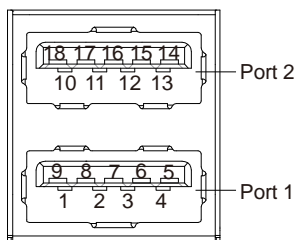

Pin	Pin Name	Signal Type	Signal Level
1	+5VSB	PWR	+5V
2	USB1_D-	DIFF	
3	USB1_D+	DIFF	
4	GND	GND	
5	USB1_SSRX-	DIFF	
6	USB1_SSRX+	DIFF	
7	GND	GND	
8	USB1_SSTX-	DIFF	
9	USB1_SSTX+	DIFF	
10	+5VSB	PWR	+5V
11	USB2_D-	DIFF	
12	USB2_D+	DIFF	
13	GND	GND	
14	USB2_SSRX-	DIFF	
15	USB2_SSRX+	DIFF	

16	GND	GND
17	USB2_SSTX-	DIFF
18	USB2_SSTX+	DIFF

## 2.49 High Definition Audio (CN32)

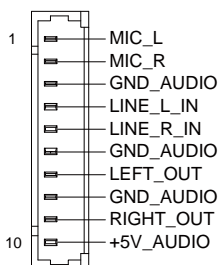

Pin	Pin Name	Signal Type	Signal Level
1	MIC_L	IN	
2	MIC_R	IN	
3	GND_AUDIO	GND	
4	LINE_L_IN	IN	
5	LINE_R_IN	IN	
6	GND_AUDIO	GND	
7	LEFT_OUT	OUT	
8	GND_AUDIO	GND	
9	RIGHT_OUT	OUT	
10	+5V_AUDIO	PWR	+5V

## 2.50 COM Port 1 (D-SUB 9) (CN33)

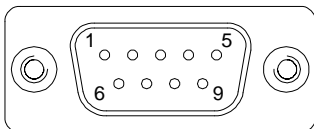

Pin	Pin Name	Signal Type	Signal Level
1	DCD	IN	
2	RX	IN	
3	TX	OUT	±9V
4	DTR	OUT	±9V
5	GND	GND	
6	DSR	IN	
7	RTS	OUT	±9V
8	CTS	IN	
9	RI	IN	

## 2.51 HDMI (CN34)

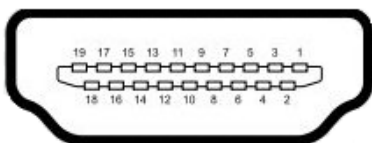

Pin	Pin Name	Signal Type	Signal Level
1	TMDS_Data2+	DIFF	
2	GND	GND	

3	TMDS_Data2-	DIFF	
4	TMDS_Data1+	DIFF	
5	GND	GND	
6	TMDS_Data1-	DIFF	
7	TMDS_Data0+	DIFF	
8	GND	GND	
9	TMDS_Data0-	DIFF	
10	TMDS_Clock+	DIFF	
11	GND	GND	
12	TMDS_Clock-	DIFF	
13	NC		
14	NC		
15	SCL	I/O	+3.3V
16	SDA	I/O	+3.3V
17	GND		
18	+5V	PWR	+5V
19	HPLG_DETECT	IN	

## 2.52 VGA / DVI Ports (depend on hardware configuration) (CN35)

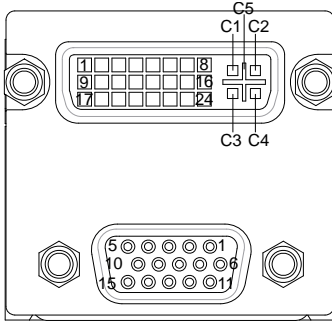

### VGA

Pin	Pin Name	Signal Type	Signal Level
1	RED	OUT	
2	GREEN	OUT	
3	BLUE	OUT	
4	NC		
5	GND	GND	
6	RED_GND_RTN	GND	
7	GREEN_GND_RTN	GND	
8	BLUE_GND_RTN	GND	
9	+5V	PWR	+5V
10	GND	GND	
11	NC		

12	DDC_DATA	I/O	+5V
13	HSYNC	OUT	
14	VSYNC	OUT	
15	DDC_CLK	I/O	+5V

## DVI

Pin	Pin Name	Signal Type	Signal Level
1	TMDS_DAT2+	DIFF	
2	TMDS_DAT2-	DIFF	
3	GND	GND	
4	VGA_DDC_CLK	I/O	
5	VGA_DDC_DATA	I/O	
6	DVI_DDC_CLK	I/O	+5V
7	DVI_DDC_DATA	I/O	+5V
8	VSYNC	OUT	
9	TMDS_DAT1-	DIFF	
10	TMDS_DAT1+	DIFF	
11	GND	GND	
12	TMDS_DAT3-	DIFF	
13	TMDS_DAT3+	DIFF	
14	+5V	PWR	+5V

15	GND	GND
16	HPLG_DETECT	IN
17	TMDS_DAT0-	DIFF
18	TMDS_DAT0+	DIFF
19	GND	GND
20	NC	
21	NC	
22	GND	GND
23	TMDS_CLK+	DIFF

## VGA

Pin	Pin Name	Signal Type	Signal Level
C1	RED	OUT	
C2	GREEN	OUT	
C3	BLUE	OUT	
C4	HSYNC	OUT	
C5	GND_ANALOG	GND	

## 2.53 UIM Socket (CN36)

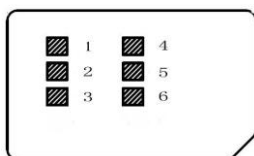

Pin	Pin Name	Signal Type	Signal Level
1	UIM_PWR	PWR	
2	UIM_RST	IN	
3	UIM_CLK	IN	
4	GND	GND	
5	UIM_VPP	PWR	
6	UIM_DATA	I/O	

## 2.54 Mini-Card (PCIE1)

Pin	Pin Name	Signal Type	Signal Level
1	PCIE_WAKE#	IN	
2	+3.3VSB	PWR	+3.3V
3	NC		
4	GND	GND	
5	NC		
6	+1.5V	PWR	+1.5V
7	PCIE_CLK_REQ#	IN	
8	UIM_PWR	PWR	
9	GND	GND	
10	UIM_DATA	I/O	
11	PCIE_REF_CLK-	DIFF	

12	UIM_CLK	IN	
13	PCIE_REF_CLK+	DIFF	
14	UIM_RST	IN	
15	GND	GND	
16	UIM_VPP	PWR	
17	NC		
18	GND	GND	
19	NC		
20	W_DISABLE#	OUT	+3.3V
21	GND	GND	
22	PCIE_RST#	OUT	+3.3V
23	PCIE_RX-	DIFF	
24	+3.3VSB	PWR	+3.3V
25	PCIE_RX+	DIFF	
26	GND	GND	
27	GND	GND	
28	+1.5V	PWR	+1.5V
29	GND	GND	
30	SMB_CLK	I/O	+3.3V
31	PCIE_TX-	DIFF	

32	SMB_DATA	I/O	+3.3V
33	PCIE_TX+	DIFF	
34	GND	GND	
35	GND	GND	
36	USB_D-	DIFF	
37	GND	GND	
38	USB_D+	DIFF	
39	+3.3VSB	PWR	+3.3V
40	GND	GND	
41	+3.3VSB	PWR	+3.3V
42	NC		
43	GND	GND	
44	NC		
45	NC		
46	NC		
47	NC		
48	+1.5V	PWR	+1.5V
49	NC		
50	GND	GND	
51	NC		

---

52	+3.3VSB	PWR	+3.3V
----	---------	-----	-------

---

## 2.55 C-FAST (CFD1)

---

Pin	Pin Name	Signal Type	Signal Level
S1	GND	GND	
S2	SATA_TX+	DIFF	
S3	SATA_TX-	DIFF	
S4	GND	GND	
S5	SATA_RX-	DIFF	
S6	SATA_RX+	DIFF	
S7	GND	GND	
PC1	NC		
PC2	GND	GND	
PC3	NC		
PC4	NC		
PC5	NC		
PC6	NC		
PC7	GND	GND	
PC8	NC		
PC9	NC		
PC10	NC		

---

---

<b>PC11</b>	NC		
<b>PC12</b>	NC		
<b>PC13</b>	+3.3V	PWR	+3.3V
<b>PC14</b>	+3.3V	PWR	+3.3V
<b>PC15</b>	GND	GND	
<b>PC16</b>	GND	GND	
<b>PC17</b>	NC		

---

## 2.56 DDR3L SO-DIMM Slot (DIMM1)

---

Standard specification

## Below Table for China RoHS Requirements

产品中有毒有害物质或元素名称及含量

## AAEON Main Board/ Daughter Board/ Backplane

部件名称	有毒有害物质或元素					
	铅 (Pb)	汞 (Hg)	镉 (Cd)	六价铬 (Cr(VI))	多溴联苯 (PBB)	多溴二苯醚 (PBDE)
印刷电路板 及其电子组件	×	○	○	○	○	○
外部信号 连接器及线材	×	○	○	○	○	○
<p><b>O:</b> 表示该有毒有害物质在该部件所有均质材料中的含量均在 SJ/T 11363-2006 标准规定的限量要求以下。</p> <p><b>X:</b> 表示该有毒有害物质至少在该部件的某一均质材料中的含量超出 SJ/T 11363-2006 标准规定的限量要求。</p> <p>备注：此产品所标示之环保使用期限，系指在一般正常使用状况下。</p>						

Chapter

3

**AMI  
BIOS Setup**

### 3.1 System Test and Initialization

---

These routines test and initialize board hardware. If the routines encounter an error during the tests, you will either hear a few short beeps or see an error message on the screen. There are two kinds of errors: fatal and non-fatal. The system can usually continue the boot up sequence with non-fatal errors.

#### **System configuration verification**

These routines check the current system configuration against the values stored in the CMOS memory. If they do not match, the program outputs an error message. You will then need to run the BIOS setup program to set the configuration information in memory.

There are three situations in which you will need to change the CMOS settings:

1. You are starting your system for the first time
2. You have changed the hardware attached to your system
3. The CMOS memory has lost power and the configuration information has been erased.

The GENE-QM87 CMOS memory has an integral lithium battery backup for data retention. However, you will need to replace the complete unit when it finally runs down.

## 3.2 AMI BIOS Setup

---

AMI BIOS ROM has a built-in Setup program that allows users to modify the basic system configuration. This type of information is stored in battery-backed CMOS RAM so that it retains the Setup information when the power is turned off.

### Entering Setup

Power on the computer and press <Del> or <F2> immediately. This will allow you to enter Setup.

### Main

Set the date, use tab to switch between date elements.

### Advanced

Advanced BIOS Features Setup including TPM, ACPI, etc.

### Chipset

Host bridge parameters.

### Boot

Enables/disable quiet boot option.

### Security

Set setup administrator password.

### Save&Exit

Exit system setup after saving the changes.

## Setup Menu

### Setup submenu: Main

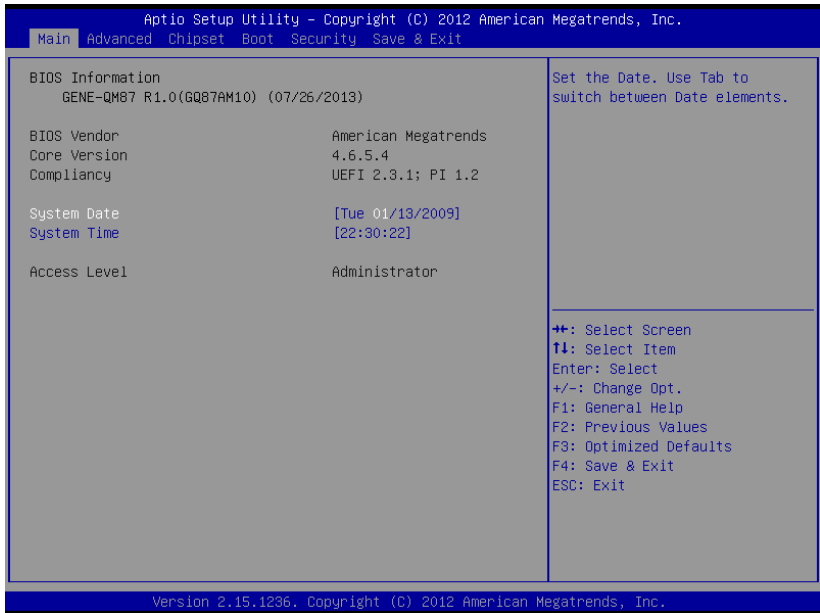

### Options summary: (**default setting**)

System Date	Day MM:DD:YYYY	
Change the month, year and century. The 'Day' is changed automatically.		
System Time	HH : MM : SS	
Change the clock of the system.		

## Setup submenu: Advanced

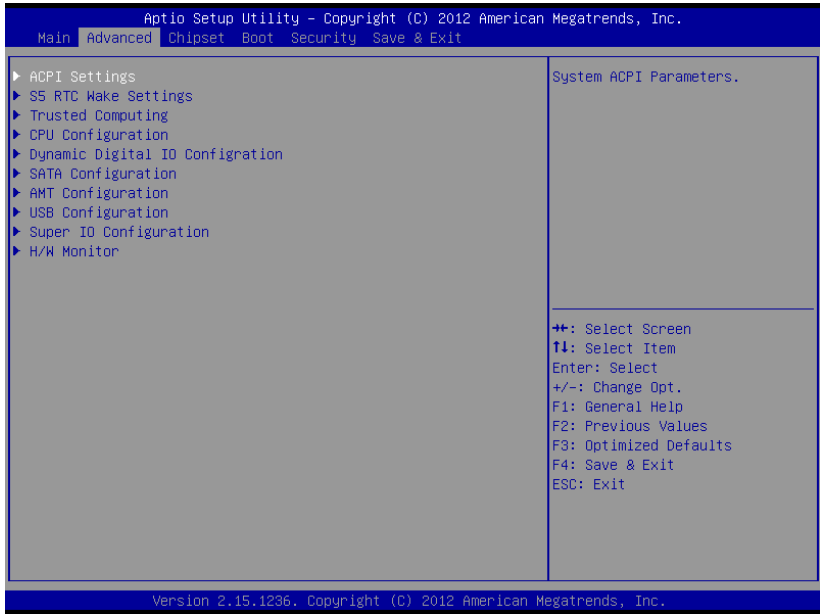
Options summary: (**default setting**)

ACPI Settings		
System ACPI Parameters		
S5 RTC Wake Settings		
Enable system to wake from S5 using RTC alarm.		
Trusted Computing		
Trusted Computing Settings		
CPU Configuration		
CPU Configuration Parameters		

Dynamic Digital IO Configuration		
DIO setting		
SATA Configuration		
SATA Device Options Settings		
AMT Configuration		
AMT Configuration Parameters		
USB Configuration		
USB Configuration Parameters		
Super IO Configuration		
Super IO Configuration Parameters		
H/W Monitor		
Monitor hardware status		

## ACPI Settings

Aptio Setup Utility - Copyright (C) 2012 American Megatrends, Inc.

Advanced

ACPI Settings		Select ACPI sleep state the system will enter when the SUSPEND button is pressed.
ACPI Sleep State	[S3 only(Suspend to ...)]	
Wake on Ring	[Enabled]	
		++: Select Screen T1: Select Item Enter: Select +/-: Change Opt. F1: General Help F2: Previous Values F3: Optimized Defaults F4: Save & Exit ESC: Exit

Version 2.15.1236. Copyright (C) 2012 American Megatrends, Inc.

Options summary: (**default setting**)

ACPI Sleep State	Suspend Disabled	
	S3 only(Suspend to RAM)	
Select the ACPI state used for System Suspend		
Wake on Ring	Disabled	
	Enabled	
Enable/Disable Wake on Ring function		

## RTC Wake Settings

Aptio Setup Utility - Copyright (C) 2012 American Megatrends, Inc.

Advanced

Wake system with Fixed Time	[Disabled]	Enable or disable System wake on alarm event. When enabled, System will wake on the hr:min::sec specified
Wake system with Dynamic Time	[Disabled]	
		++: Select Screen ↑↓: Select Item Enter: Select +/-: Change Opt. F1: General Help F2: Previous Values F3: Optimized Defaults F4: Save & Exit ESC: Exit

Version 2.15.1236. Copyright (C) 2012 American Megatrends, Inc.

Options summary: (**default setting**)

Wake system with	<b>Disabled</b>	
Fixed Time	Enabled	
Enable or disable System wake on alarm event. Wake up time is setting by following settings.		
Wake up day	0-31	
Select 0 for daily system wake up		
Wake up hour	0-23	
Wake up minute	0-59	

Wake up second	0-59	
Wake system with	<b>Disabled</b>	
Dynamic Time	Enabled	
Enable or disable System wake on alarm event. Wake up time is current time + Increase minutes.		
Wake up minute increase	1-5	

## Trusted Computing

Aptio Setup Utility - Copyright (C) 2012 American Megatrends, Inc.

Advanced

<p>Configuration</p> <p>Security Device Support [Disable]</p> <p>Current Status Information</p> <p>SUPPORT TURNED OFF</p>	<p>Enables or Disables BIOS support for security device. O.S. will not show Security Device. TCG EFI protocol and INT1A interface will not be available.</p>
<p>           ++: Select Screen            ↑↓: Select Item            Enter: Select            +/-: Change Opt.            F1: General Help            F2: Previous Values            F3: Optimized Defaults            F4: Save &amp; Exit            ESC: Exit         </p>	

Version 2.15.1236. Copyright (C) 2012 American Megatrends, Inc.

### Options summary: (*default setting*)

Security Device Support	<b>Disabled</b>	
	Enabled	
En/Disable TPM support.		
TPM State	<b>Disabled</b>	
	Enabled	
En/Disable TPM functionality.		
Pending TPM Operation	<b>None</b>	
	Enable Take Ownership	

	Disable Take Ownership	
	TPM Clear	

Select one-time TPM operation. Item value returns to 'None' after next POST.

## CPU Configuration

Aptio Setup Utility - Copyright (C) 2012 American Megatrends, Inc.

Advanced

CPU Signature	306c3	Enables or Disables Intel(R) TXT(LT) support.
Microcode Patch	8	
Max CPU Speed	1600 MHz	
Min CPU Speed	800 MHz	
CPU Speed	2600 MHz	
Processor Cores	2	
Intel HT Technology	Supported	
Intel VT-x Technology	Supported	
Intel SMX Technology	Supported	
64-bit	Supported	
EIST Technology	Supported	
CPU C3 state	Supported	
CPU C6 state	Supported	
CPU C7 state	Supported	
L1 Data Cache	32 kB x 2	
L1 Code Cache	32 kB x 2	
L2 Cache	256 kB x 2	
L3 Cache	3072 kB	
Hyper-threading	[Enabled]	
Active Processor Cores	[All]	
Intel Virtualization Technology	[Enabled]	
EIST	[Enabled]	
Intel TXT(LT) Support	[Disabled]	

++: Select Screen  
 F1: Select Item  
 Enter: Select  
 +/-: Change Opt.  
 F1: General Help  
 F2: Previous Values  
 F3: Optimized Defaults  
 F4: Save & Exit  
 ESC: Exit

Version 2.15.1236. Copyright (C) 2012 American Megatrends, Inc.

### Options summary: (**default setting**)

Hyper-Threading	Disabled	
	<b>Enabled</b>	
En/Disable CPU Hyper-Threading function		

Active Processor Cores	<b>ALL</b>	
	1 to Max CPU cores	
Number of CPU cores to be active.		
Intel Virtualization Technology	Disabled	
	<b>Enabled</b>	
En/Disable Intel VT-x function		
EIST	Disabled	
	<b>Enabled</b>	
En/Disable Intel SpeedStep		
Intel TXT(LT) Support	<b>Disabled</b>	
	Enabled	
En/Disable Intel TXT(LT)		

## Dynamic Digital IO Configuration

Aptio Setup Utility - Copyright (C) 2012 American Megatrends, Inc.

Advanced

Base Address:		Set digital IO port as Input or Output
Digital Port 1(GP50) Direction	[Input]	
Digital Port 2(GP51) Direction	[Input]	
Digital Port 3(GP52) Direction	[Input]	
Digital Port 4(GP53) Direction	[Input]	
Digital Port 5(GP54) Direction	[Output]	
Digital Port 5(GP54) Level	[Hi]	
Digital Port 6(GP55) Direction	[Output]	
Digital Port 6(GP55) Level	[Hi]	++: Select Screen ↑↓: Select Item Enter: Select +/-: Change Opt. F1: General Help F2: Previous Values F3: Optimized Defaults F4: Save & Exit ESC: Exit
Digital Port 7(GP56) Direction	[Output]	
Digital Port 7(GP56) Level	[Hi]	
Digital Port 8(GP57) Direction	[Output]	
Digital Port 8(GP57) Level	[Hi]	

Version 2.15.1236. Copyright (C) 2012 American Megatrends, Inc.

Options summary: (**default setting**)

Digital Port X(GPXX)	Input	
Direction	Output	
Set GPIOx as Input or Output		
Digital Port X(GPXX)	<b>Hi</b>	
Levels	Low	
Set GPIO output level when used as output pin		

## SATA Configuration

Aptio Setup Utility - Copyright (C) 2012 American Megatrends, Inc.

Advanced

SATA Controller(s)	[Enabled]	Enable or disable SATA Device.
SATA Mode Selection	[AHCI]	
Serial ATA Port 0	Empty	++: Select Screen !: Select Item Enter: Select +/-: Change Opt. F1: General Help F2: Previous Values F3: Optimized Defaults F4: Save & Exit ESC: Exit
Software Preserve	Unknown	
Port 0	[Enabled]	
Hot Plug	[Enabled]	
Serial ATA Port 1	Empty	
Software Preserve	Unknown	
Port 1	[Enabled]	
Hot Plug	[Enabled]	
Serial ATA Port 2	Empty	
Software Preserve	Unknown	
Port 2	[Enabled]	
Hot Plug	[Enabled]	
Serial ATA Port 4	Empty	
Software Preserve	Unknown	
Port 4	[Enabled]	
Hot Plug	[Enabled]	

Version 2.15.1236. Copyright (C) 2012 American Megatrends, Inc.

### Options summary: (*default setting*)

SATA Controller(s)	Disabled	
	<b>Enabled</b>	
En/Disable SATA controller		
SATA Mode Selection	IDE	
	<b>AHCI</b>	
	RAID	
Configure SATA controller operating as IDE/AHCI/RAID mode.		
Port X	Disabled	
	<b>Enabled</b>	

En/Disable the selected port.

Hot Plug

Disabled

***Enabled***

En/Disable Hot Plug feature for specified port.

## AMT Configuration

Aptio Setup Utility - Copyright (C) 2012 American Megatrends, Inc.

Advanced

Intel AMT	[Enabled]	Enable/Disable Intel (R) Active Management Technology BIOS Extension. Note : iAMT H/W is always enabled. This option just controls the BIOS extension execution. If enabled, this requires additional firmware in the SPI device
Un-Configure ME	[Disabled]	

++: Select Screen  
 ↑↓: Select Item  
 Enter: Select  
 +/-: Change Opt.  
 F1: General Help  
 F2: Previous Values  
 F3: Optimized Defaults  
 F4: Save & Exit  
 ESC: Exit

Version 2.15.1236. Copyright (C) 2012 American Megatrends, Inc.

### Options summary: (*default setting*)

Intel AMT	<b>Enabled</b>	
	Disabled	
En/Disable Intel® Active Management Technology BIOS Extension. Note: iAMT H/W is always enabled. This option just controls the BIOS extension execution. If enabled, this requires additional firmware in the SPI device		
Un-Configure ME	Enabled	
	<b>Disabled</b>	
OEMFlag Bit 15: Un-Configure ME without password		

## USB Configuration

Aptio Setup Utility - Copyright (C) 2012 American Megatrends, Inc.

Advanced

USB Configuration		Enables Legacy USB support. AUTO option disables legacy support if no USB devices are connected. DISABLE option will keep USB devices available only for EFI applications.
USB Module Version	8.10.27	
USB Devices: 3 Drives, 1 Keyboard, 2 Mice, 1 Point, 2 Hubs		
Legacy USB Support	[Enabled]	++: Select Screen T1: Select Item Enter: Select +/-: Change Opt. F1: General Help F2: Previous Values F3: Optimized Defaults F4: Save & Exit ESC: Exit
USB3.0 Support	[Enabled]	
Mass Storage Devices:		
Generic STORAGE DEVICE 9602	[Auto]	
Generic STORAGE DEVICE 9602	[Auto]	
Generic STORAGE DEVICE 9602	[Auto]	

Version 2.15.1236. Copyright (C) 2012 American Megatrends, Inc.

### Options summary: (**default setting**)

Legacy USB Support	<b>Enabled</b>	
	Disabled	
	Auto	
Enables BIOS Support for Legacy USB Support. When enabled, USB can be functional in legacy environment like DOS. AUTO option disables legacy support if no USB devices are connected. DISABLE option will keep USB devices available only for EFI application		
USB3.0 Support	<b>Enabled</b>	

	Disabled	
Enables BIOS Support for USB3.0 (XHCI). When disabled, PCH USB3.0 controller will also be disabled.		
Device Name (Emulation Type)	Auto	
	Floppy	
	Forced FDD	
	Hard Disk	
	CD-ROM	
If Auto. USB devices less than 530MB will be emulated as Floppy and remaining as Floppy and remaining as hard drive. Forced FDD option can be used to force a HDD formatted drive to boot as FDD(Ex. ZIP drive)		



## Serial Port X Configuration

Aptio Setup Utility - Copyright (C) 2012 American Megatrends, Inc.

Advanced

Serial Port 2 Configuration		Enable or Disable Serial Port (COM)
Serial Port	[Enabled]	
Device Settings	IO=2F8h; IRQ=3;	
Change Settings	[Auto]	
COM2 Type Select	[RS232]	
		++: Select Screen ↑↓: Select Item Enter: Select +/-: Change Opt. F1: General Help F2: Previous Values F3: Optimized Defaults F4: Save & Exit ESC: Exit

Version 2.15.1236. Copyright (C) 2012 American Megatrends, Inc.

Options summary: (*default setting*)

Serial Port	Disabled	
	<b>Enabled</b>	
En/Disable specified serial port.		
Change Settings	<b>Auto</b>	
	IO=2F8h; IRQ=3;	
	IO=3F8h; IRQ=3,4,5,7,10,11,12;	
	IO=2F8h; IRQ=3,4,5,7,10,11,12;	

	IO=3E8h; IRQ=3,4,5,7,10,11,12;	
	IO=2E8h; IRQ=3,4,5,7,10,11,12;	
Select a resource setting for Super IO device.		
Device Type	<b>RS232</b>	
	RS422	
	RS485	
Configure COM2/6 operated as RS232, RS422 or RS485.		

## H/W Monitor

Aptio Setup Utility - Copyright (C) 2012 American Megatrends, Inc.

Advanced

<p>Pc Health Status</p> <p>Smart Fan Function [Enabled]</p> <p>▶ Smart Fan Mode Configuration</p> <p>System temperature : +32 ℃</p> <p>System temperature : +32 ℃</p> <p>CPU temperature : +36 ℃</p> <p>CPU Fan Speed : 4885 RPM</p> <p>Vcore : +1.728 V</p> <p>V12V : +11.666 V</p> <p>V5V : +5.101 V</p> <p>Vdimm : +1.351 V</p> <p>VBAT : +3.219 V</p>	<p>Enable or Disable Smart Fan</p> <p>++: Select Screen</p> <p>↑↓: Select Item</p> <p>Enter: Select</p> <p>+/-: Change Opt.</p> <p>F1: General Help</p> <p>F2: Previous Values</p> <p>F3: Optimized Defaults</p> <p>F4: Save &amp; Exit</p> <p>ESD: Exit</p>
---	--

Version 2.15.1236. Copyright (C) 2012 American Megatrends, Inc.

Options summary: (**default setting**)

Smart Fan Function	Disabled	
	<b>Enabled</b>	
Enable or Disable Smart Fan		
Smart Fan Mode configuration		
Smart Fan Mode select		

## Smart Fan Mode configuration

Aptio Setup Utility - Copyright (C) 2012 American Megatrends, Inc.

Advanced

Smart Fan Mode Configuration		Smart Fan Mode Select
CPU Smart Fan Control	[Auto Duty-Cycle Mode]	
Temperature 1	60	
Temperature 2	50	
Temperature 3	40	
Temperature 4	30	
Duty Cycle 0	100	
Duty Cycle 1	85	
Duty Cycle 2	70	
Duty Cycle 3	60	
Duty Cycle 4	50	
		++: Select Screen ↑↓: Select Item Enter: Select +/-: Change Opt. F1: General Help F2: Previous Values F3: Optimized Defaults F4: Save & Exit ESC: Exit

Version 2.15.1236. Copyright (C) 2012 American Megatrends, Inc.

Options summary: (**default setting**)

CPU Smart Fan Control	<b>Manual Duty Mode</b>	
	Auto Duty-Cycle Mode	
Manual Duty Mode: Manually controlling the fan with a given control PWM.		
Auto Duty-Cycle Mode: Automatically controlling the fan with given parameters.		
Manual Duty Mode	1 to 100, default is <b>80</b>	
Fan Speed value between 1 to 100		

Temperature 1/2/3/4	1 to 100, default is <b>60/50/40/30</b>	
Auto fan speed control. Fan speed will follow different temperature by different duty cycle 1-100		
Duty Cycle 0/1/2/3/4	1 to 100, default is <b>100/85/70/60/50</b>	
Auto fan speed control. Fan speed will follow different temperature by different duty cycle 1-100		

## Setup submenu: Chipset

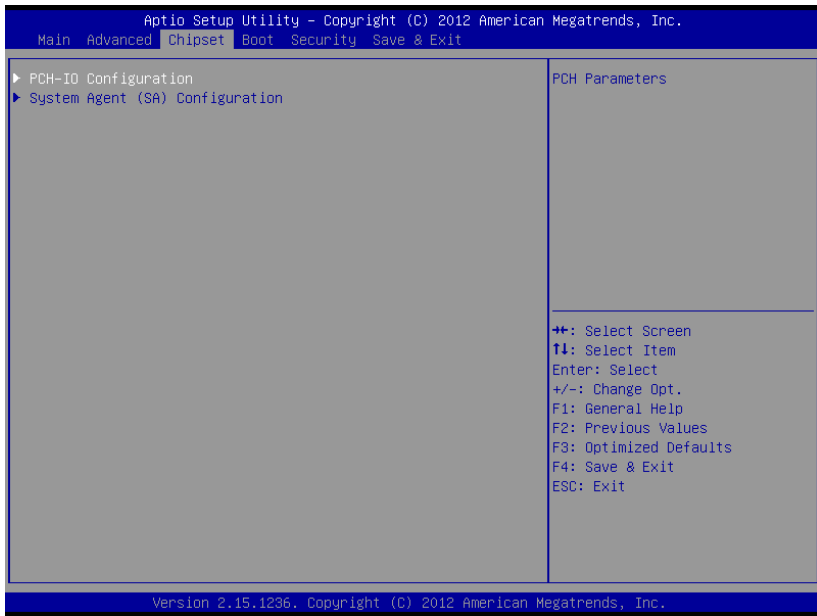

Options summary: (**default setting**)

PCH-IO Configuration		
South Bridge Parameters		
System Agent (SA) Configuration		
SA Parameters		

## PCH-IO Configuration

Aptio Setup Utility - Copyright (C) 2012 American Megatrends, Inc.

Chipset

Intel PCH RC Version	1.4.0.0	Enable or disable 'It is now safe to turn off your computer.' string
Intel PCH SKU Name	QM87	
Intel PCH Rev ID	04/C1	
Power Mode	[ATX Type]	
▶ PCI Express Configuration		
PCH LAN Controller	[Enabled]	<b>++:</b> Select Screen <b>T1:</b> Select Item Enter: Select +/-: Change Opt. F1: General Help F2: Previous Values F3: Optimized Defaults F4: Save & Exit ESC: Exit
Wake on LAN	[Enabled]	
Restore AC Power Loss	[Power Off]	

Version 2.15.1236, Copyright (C) 2012 American Megatrends, Inc.

Options summary: (**default setting**)

Power Mode	<b>ATX Type</b>	
	AT Type	
Enable or disable 'It is now safe to turn off your computer.' string		
PCI Express Configuration		
PCI Express Configuration settings		
PCH LAN Controller	<b>Enabled</b>	
	Disabled	
En/Disabled onboard NIC		
Wake on LAN	<b>Enabled</b>	
	Disabled	
En/Disabled integrated LAN to wake the system. (The Wake on LAN cannot be disabled if ME is on at Sx state.)		
Restore AC Power Loss	<b>Power Off</b>	
	Power On	
	Last State	
Select AC power state when power is re-applied after a power failure		

## System Agent (SA) Configuration

Aptio Setup Utility - Copyright (C) 2012 American Megatrends, Inc.

Chipset

System Agent Bridge Name	Haswell	Check to enable VT-d function on MCH.
System Agent RC Version	1.4.0.0	
VT-d Capability	Supported	
VT-d	[Enabled]	
CPU SA Audio Device (B0:D3:F0)	[Enabled]	
▶ Graphics Configuration		
++: Select Screen ↑↓: Select Item Enter: Select +/-: Change Opt. F1: General Help F2: Previous Values F3: Optimized Defaults F4: Save & Exit ESC: Exit		

Version 2.15.1236. Copyright (C) 2012 American Megatrends, Inc.

Options summary: (*default setting*)

VT-d	<b>Disabled</b>	
	Enabled	
Check to enable VT-d function on MCH		
CPU SA Audio Device (B0:D3:F0)	<b>Enabled</b>	
	Disabled	
En/Disable CPU SA Audio Device		
Graphics Configuration		
Config Graphics Settings		

## Graphics Configuration

Aptio Setup Utility - Copyright (C) 2012 American Megatrends, Inc.

Chipset

Graphics Configuration		Graphics turbo IMON current values supported (14-31)
IGFX VBIOS Version	2170	
IGfx Frequency	800 MHz	
Graphics Turbo IMON Current	<b>31</b>	
Primary Display	[Auto]	
Internal Graphics	[Auto]	
DVMT Pre-Allocated	[32M]	
DVMT Total Gfx Mem	[MAX]	
▶ LCD Control		

++: Select Screen  
 ↑↓: Select Item  
 Enter: Select  
 +/-: Change Opt.  
 F1: General Help  
 F2: Previous Values  
 F3: Optimized Defaults  
 F4: Save & Exit  
 ESC: Exit

Version 2.15.1236. Copyright (C) 2012 American Megatrends, Inc.

Options summary: (*default setting*)

Primary Display	<b>Auto</b>	
	IGFX	
	PEG	
	PCIE	
	SG	
Select graphic adapters to boot		
Internal Graphics	<b>Auto</b>	
	Disabled	
	Enabled	

En/Disabled internal graphics device		
DVMT	<b>32MB</b>	
Pre-Allocated	64MB~1024MB	
Select DVMT 5.0 Pre-Allocated (Fixed) Graphics Memory size used by the Internal Graphics Device.		
DVMT Total Gfx	128MB	
Mem	256MB	
	<b>Max</b>	
Select DVMT 5.0 Total Graphic Memory size used by the Internal Graphics Device.		

## LCD Control

Aptio Setup Utility - Copyright (C) 2012 American Megatrends, Inc.		
Chipset		
LCD Control		Select the Video Device which will be activated during POST. This has no effect if external graphics present.
Primary IGFX Boot Display	[VBIOS Default]	Secondary boot display selection will appear based on your selection.
LVDS1 Control	[Disabled]	VGA modes will be supported only on primary display
LVDS2 Control	[Disabled]	
		++: Select Screen ↑↓: Select Item Enter: Select +/-: Change Opt. F1: General Help F2: Previous Values F3: Optimized Defaults F4: Save & Exit ESC: Exit
Version 2.15.1236. Copyright (C) 2012 American Megatrends, Inc.		

Options summary: (**default setting**)

Primary IGFX Boot Display	<b>VBIOS Defat</b>	
	CRT	
	LVDS2	
	LVDS1	
	DVI	
	HDM	
Select Primary IGFX boot display device		
LVDS1 Control	<b>Disabled</b>	

	Enabled	
Enable or Disable Onboard PTN3460(EDP)		
LVDS2 Control	<b>Disabled</b>	
	Enabled	
Enable or Disable Onboard PTN3460(DP)		
LVDS1 Panel Type	640x480, 18-Bit, 60Hz	
	800x480, 18-Bit, 60Hz	
	800x600, 18-Bit, 60Hz	
	1024x600, 18-Bit, 60Hz	
	1024x768, 18-Bit, 60Hz	
	1024x768, 24-Bit, 60Hz	
	1280x768, 24-Bit, 60Hz	
	1280x1024, 48-Bit, 60Hz	
	1366x768, 24-Bit, 60Hz	
	1440x900, 24Bit, 60Hz	
	1600x1200, 48-Bit, 60Hz	
	1920x1080, 48-Bit, 60Hz	
	640x480, 24-Bit, 60Hz	
	800x600, 24-Bit, 60Hz	
	1280x768, 18-Bit, 60Hz	
Select LVDS1 native resolution.		
LVDS2 Panel Type	<b>800x600, 18-Bit, 60Hz</b>	
	1024x768, 18-Bit, 60Hz	
	1280x768, 18-Bit, 60Hz	

	1366x768,18-Bit,60Hz	
	1280x1024,48-Bit,60Hz	
	1920x1080,48-Bit,60Hz	
	1920x1200,48-Bit,60Hz	
	800x600,24-Bit,60Hz	
	1024x768,24-Bit,60Hz	
	1280x768,24-Bit,60Hz	
	1388x768,24-Bit,60Hz	
Select LVDS2 native resolution.		
LVDS1/LVDS2	Inverted	
Backlight Type	<b>Normal</b>	
Select Backlight control type.		
Inverted: Brightest for low PWM duty cycle and low voltage.		
Normal: Brightest for high PWM duty cycle and high voltage.		
LVDS1/LVDS2	100%	
Backlight Level	90%	
	<b>80%</b>	
	70%	
	60%	
	50%	
	40%	
	30%	
	20%	
	10%	

	0%	
Select Backlight Level		

## Setup submenu: Boot

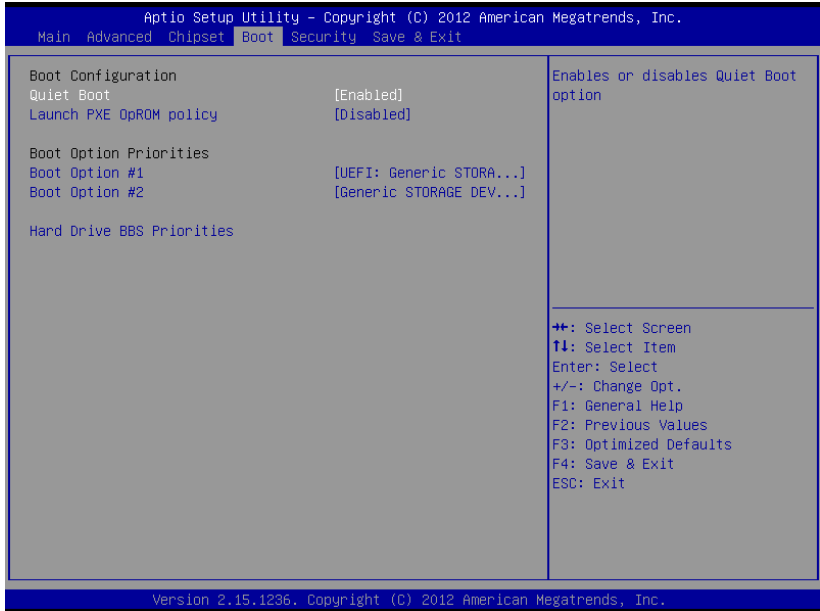

### Options summary: (*default setting*)

Quiet Boot	Disabled	
	<b>Enabled</b>	
En/Disable showing boot logo.		
Launch PXE OpROM policy	<b>Disabled</b>	
	Enabled	
En/Disable PXE boot for LAN		

Boot Option #X/  
XXXX Drive BBS  
Priorities

The order of boot priorities.

### BBS Priorities

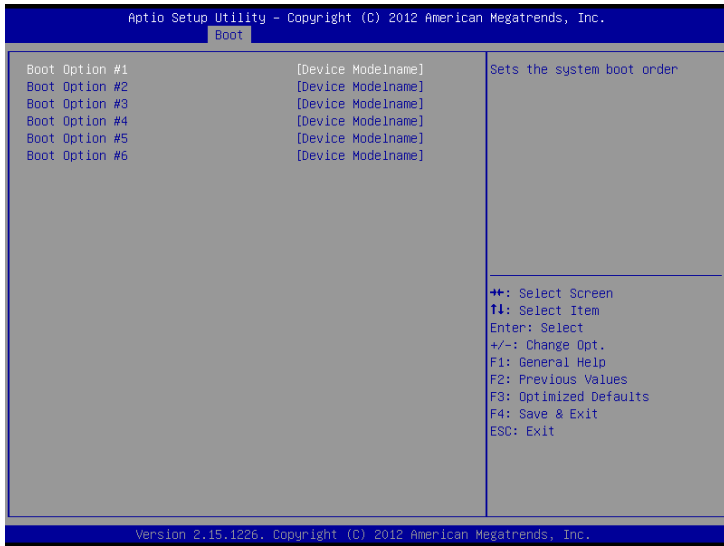

Options summary: (**default setting**)

Boot Option #x	Disabled	
	Device name	
Sets the system boot order		

## Setup submenu: Security

Aptio Setup Utility - Copyright (C) 2012 American Megatrends, Inc.

Main Advanced Chipset Boot **Security** Save & Exit

<p>Password Description</p> <p>If ONLY the Administrator's password is set, then this only limits access to Setup and is only asked for when entering Setup.</p> <p>If ONLY the User's password is set, then this is a power on password and must be entered to boot or enter Setup. In Setup the User will have Administrator rights.</p> <p>The password length must be in the following range:</p> <table> <tr> <td>Minimum length</td> <td>3</td> </tr> <tr> <td>Maximum length</td> <td>20</td> </tr> </table> <p>Administrator Password User Password</p> <p>► Secure Boot menu</p>	Minimum length	3	Maximum length	20	<p>Set Administrator Password</p> <hr/> <p>           ++: Select Screen            ↑↓: Select Item            Enter: Select            +/-: Change Opt.            F1: General Help            F2: Previous Values            F3: Optimized Defaults            F4: Save &amp; Exit            ESC: Exit         </p>
Minimum length	3				
Maximum length	20				

Version 2.15.1236. Copyright (C) 2012 American Megatrends, Inc.

### Options summary: (*default setting*)

Administrator	<b>Not set</b>	
Password/ User Password		

You can install a Supervisor password, and if you install a supervisor password, you can then install a user password. A user password does not provide access to many of the features in the Setup utility.

*Install the Password:*

Press Enter on this item, a dialog box appears which lets you enter a password. You can enter no more than six letters or numbers. Press Enter after you have typed in the password. A second dialog box asks you to retype the password for confirmation. Press Enter after you have retyped it correctly. The password is required at boot time, or when the user enters the Setup utility.

*Removing the Password:*

Highlight this item and type in the current password. At the next dialog box press Enter to disable password protection.

## Setup submenu: Exit

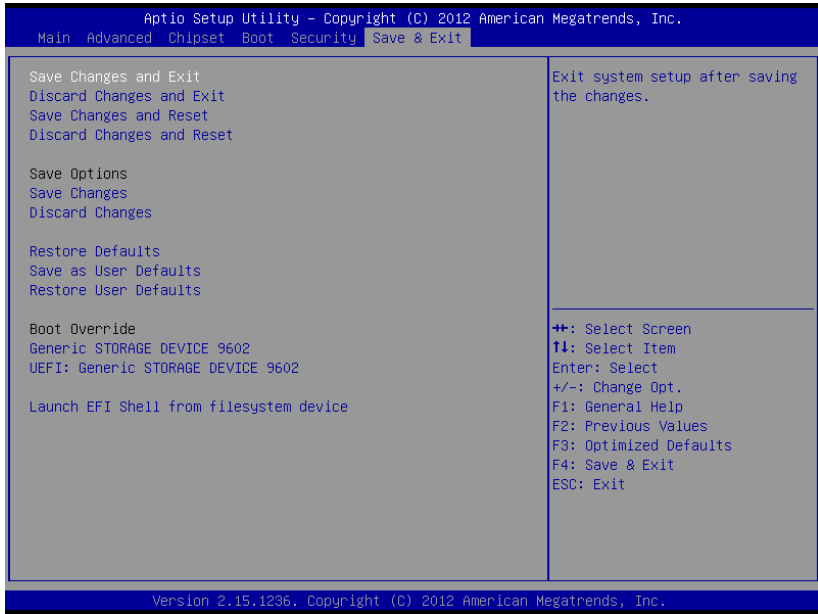

### Options summary: (*default setting*)

Save Changes and Exit		
Exit system setup after saving the changes		
Discard Changes and Exit		
Exit system setup without saving any changes		
Save Changes and Reset		
Reset the system after saving the changes		

Discard Changes and Reset		
Save Changes		
Save Changes done so far to any of the setup options.		
Discard Changes		
Discard Changes done so far to any of the setup options		
Reset system setup without saving any changes		
Restore Defaults		
Restore/Load Default values for all the setup options.		
Save as User Defaults		
Save the changes done so far as User Defaults		
Restore User Defaults		
Restore the User Defaults to all the setup options		

Chapter

4

**Driver  
Installation**

The GENE-QM87 comes with an AutoRun DVD-ROM that contains all drivers and utilities that can help you to install the driver automatically.

Insert the driver DVD, the driver DVD-title will auto start and show the installation guide. If not, please follow the sequence below to install the drivers.

***Follow the sequence below to install the drivers:***

- Step 1 – Install CHIPSET Driver
- Step 2 – Install VGA Driver
- Step 3 – Install LAN Driver
- Step 4 – Install AUDIO Driver
- Step 5 – Install ME Driver
- Step 6 – Install TPM Driver
- Step 7 – Install TOUCH Driver
- Step 8 – Install USB3.0 Driver
- Step 9 – Install IRST Driver
- Step 10 – Install Serial Port Driver (Optional)

Please read instructions below for further detailed installations.

## 4.1 Installation:

---

Insert the GENE-QM87 DVD-ROM into the DVD-ROM drive. And install the drivers from Step 1 to Step 10 in order.

### Step 1 – Install Chipset Driver

1. Click on the **STEP 1-CHIPSET** folder and select the OS folder your system is
2. Double click on the **infinst\_autol.exe** file located in each OS folder
3. Follow the instructions that the window shows
4. The system will help you install the driver automatically

### Step 2 – Install VGA Driver

1. Click on the **STEP2-VGA** folder and select the OS folder your system is
2. Double click on the **Setup.exe** file located in each OS folder
3. Follow the instructions that the window shows
4. The system will help you install the driver automatically

#### **Note 1:**

- This motherboard supports VGA and LVDS display devices. In Single Display mode, use the hot keys to switch between VGA to LVDS device or vice versa. By default, press **<Ctrl>+<Alt>+<F1>** to switch to VGA device and press **<Ctrl>+<Alt>+<F3>** to switch to LVDS device.
- Before removing the current display device, connect the display device that you want to use, and then press the hot keys to switch to that device.

**Note 2:** If the OS is Windows® XP, you have to install the driver of dotNet Framework first. Simply click on **dotnetfx35.exe** located in **dotNet Framework** folder.

### Step 3 –Install LAN Driver

1. Click on the **STEP3-LAN** folder and select the OS folder your system is
2. Double click on the **Autorun.exe** file located in each OS folder
3. Follow the instructions that the window shows
4. The system will help you install the driver automatically

### Step 4 –Install AUDIO Driver

1. Click on the **STEP4-AUDIO** folder and select the OS folder your system is
2. Double click on the **Setup.exe** file located in each OS folder
3. Follow the instructions that the window shows
4. The system will help you install the driver automatically

### Step 5 – Install ME Driver

1. Click on the **STEP5-ME SW** folder and select the OS folder your system is
2. Double click on the **Setup.exe** file located in each OS folder
3. Follow the instructions that the window shows
4. The system will help you install the driver automatically

#### Step 6 – Install TPM Driver

1. Click on the **STEP6-TPM** folder and select the OS folder your system is
2. Double click on the **Setup.exe** file located in each OS folder
3. Follow the instructions that the window shows
4. The system will help you install the driver automatically

#### Step 7 –Install TOUCH Driver

1. Click on the **STEP7-TOUCH** folder and select the OS folder your system is
2. Double click on the **Setup.exe** file located in each OS folder
3. Follow the instructions that the window shows
4. The system will help you install the driver automatically

#### Step 8 –Install USB3.0 Driver (Windows 7 only)

1. Click on the **STEP8-USB3.0** folder and select the OS folder your system is
2. Double click on the **Setup.exe** file located in each OS folder
3. Follow the instructions that the window shows
4. The system will help you install the driver automatically

### Step 9 – Install IRST Driver

1. Click on the **STEP9-IRST** folder and select the OS folder your system is
2. Double click on the **SetupRST.exe** file located in each OS folder
3. Follow the instructions that the window shows
4. The system will help you install the driver automatically

### Step 10 – Install Serial Port Driver (Optional)

1. Click on the **STEP10- Serial Port** folder and select the OS folder your system is
2. Double click on **patch.bat** file
3. Follow the instructions that the window shows
4. The system will help you install the driver automatically

Appendix

**A**

# Programming the Watchdog Timer

## A.1 Programming

GENE-QM87 utilizes FINTEK 81866 chipset as its watchdog timer controller. Below are the procedures to complete its configuration and the AAEON initial watchdog timer program is also attached based on which you can develop customized program to fit your application.

### Configuring Sequence Description

After the hardware reset or power-on reset, the FINTEK 81866 enters the normal mode with all logical devices disabled except KBC. The initial state (enable bit) of this logical device (KBC) is determined by the state of pin 121 (DTR1#) at the falling edge of the system reset during power-on reset.

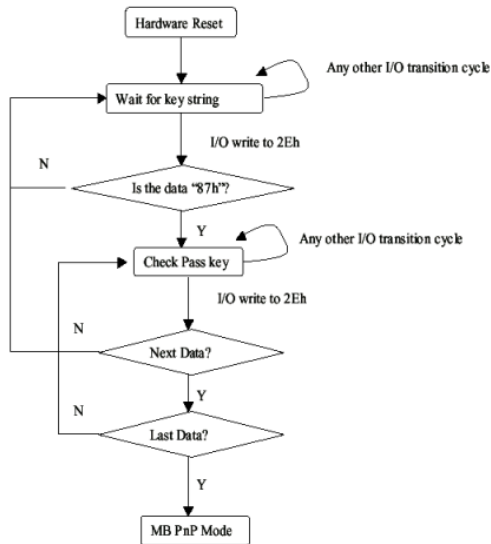

There are three steps to complete the configuration setup: (1) Enter the MB PnP Mode; (2) Modify the data of configuration registers; (3) Exit the MB PnP Mode. Undesired result may occur if the MB PnP Mode is not exited normally.

### (1) Enter the MB PnP Mode

To enter the MB PnP Mode, four special I/O write operations are to be performed during Wait for Key state. To ensure the initial state of the key-check logic, it is necessary to perform four write operations to the Special Address port (2EH). Two different enter keys are provided to select configuration ports (2Eh/2Fh) of the next step.

-o 4e 87

-o 4e 87                   ( enable configuration )

### (2) Modify the Data of the Registers

All configuration registers can be accessed after entering the MB PnP Mode. Before accessing a selected register, the content of Index 07h must be changed to the LDN to which the register belongs, except some Global registers.

### (3) Exit the MB PnP Mode

Write exit key 0xAA to the index port.

-o 4e aa                   ( disable configuration )

## Watch Dog Timer 1, 2, 3 Control Register (Index=F5h,F6h,FAh Default=00h)

### 7.8.4 Watchdog Control Configuration Register 1 — Index F5h

Bit	Name	R/W	Reset	Default	Description
7	Reserved	R	-	0	Reserved
6	WDTMOUT_STS	R/W	5VSB	0	If watchdog timeout event occurred, this bit will be set to 1. Write a 1 to this bit will clear it to 0.
5	WD_EN	R/W	5VSB	0	If this bit is set to 1, the counting of watchdog time is enabled.
4	WD_PULSE	R/W	5VSB	0	Select output mode (0: level, 1: pulse) of RSTOUT# by setting this bit.
3	WD_UNIT	R/W	5VSB	0	Select time unit (0: 1sec, 1: 60 sec) of watchdog timer by setting this bit.
2	WD_HACTIVE	R/W	5VSB	0	Select output polarity of RSTOUT# (1: high active, 0: low active) by setting this bit.
1-0	WD_PSWIDTH	R/W	5VSB	0	Select output pulse width of RSTOUT# 0: 1 ms            1: 25 ms 2: 125 ms        3: 5 sec

### 7.8.5 Watchdog Timer Configuration Register 2 — Index F6h

Bit	Name	R/W	Reset	Default	Description
7-0	WD_TIME	R/W	5VSB	0	Time of watchdog timer (0-255)

### 7.8.6 Watchdog PME Enable Configuration Register 2 — Index FAh

Bit	Name	R/W	Reset	Default	Description
7	WDT_PME	R	5VSB	0	0: No WDT PME occurred. 1: WDT PME occurred. The WDT PME is occurred one unit before WDT timeout.
6	WDT_PME_EN	R/W	5VSB	0	0: Disable Watchdog PME. 1: enable Watchdog PME.
5	Reserved	R	-	0	Reserved
4	WDT_CLK_SEL	R/W	5VSB	1	WDT Clock Source Select 0: Internal 1KHz clock. 1: 1KHZ clock driven by CLKIN.
3-1	Reserved	R	-	0	Reserved
0	WDOUT_EN	R/W	5VSB	0	0: disable Watchdog time out output via WDTRST#. 1: enable Watchdog time out output via WDTRST#.

## A.2 F81866 Watchdog Timer Initial Program

---

```
Main(){
```

```
aaeonSuperIOOpen();
```

```
aaeonWdtSetCountMode(BOOL bMinute); // Set wdt count mode
```

```
aaeonWdtSetTimeoutCount(BYTE tTimeout); // Set wdt timer
```

```
aaeonWdtSetEnable(BOOL bEnable); // Enable wdt
```

```
aaeonSuperIOClose();
```

```
}
```

```
Void aaeonSuperIOOpen(){ // Config F81866 Entry key
```

```
    aaeonioWritePortByte(F81866_INDEX, 0x87);
```

```
    aaeonioWritePortByte(F81866_INDEX, 0x87);
```

```
}
```

```
Void aaeonWdtSetCountMode(BOOL bMinute){
```

```
    BYTE WDT_CONTROL = f81866ReadByte(F81866_WDT_CONTROL_REG);
```

```
    if(bMinute)
```

```
        f81866WriteByte(F81866_WDT_CONTROL_REG, WDT_CONTROL | 0x08);
```

```
    else
```

```
        f81866WriteByte(F81866_WDT_CONTROL_REG, WDT_CONTROL & 0xF7);
```

```
}
```

```
Void aaeonWdtSetTimeoutCount(BYTE tTimeout){
    f81866SetLdn(0x07);
    f81866WriteByte(F81866_WDT_TIME_REG, tTimeout);
}

Void aaeonWdtSetEnable(BOOL bEnable){
    f81866SetLdn(0x07);
    if(bEnable){
        f81866WriteByte(0x30, 0x01);
        WDT_BASE_ADDR =
            (f81866ReadByte(F81866_WDT_BASEADDR_REG_MSB) << 8)
            | f81866ReadByte(F81866_WDT_BASEADDR_REG_LSB);
        WDT_STATUS = f81866ReadByte(F81866_WDT_CONTROL_REG);
        f81866WriteByte(F81866_WDT_CONTROL_REG, WDT_STATUS | 0x20);
        WDT_STATUS = f81866ReadByte(F81866_WDT_PME_REG);
        f81866WriteByte(F81866_WDT_PME_REG, WDT_STATUS | 0x01);
    }else{
        f81866WriteByte(0x30, 0x00);
        WDT_BASE_ADDR = 0;
        WDT_STATUS = f81866ReadByte(F81866_WDT_CONTROL_REG);
        f81866WriteByte(F81866_WDT_CONTROL_REG, WDT_STATUS & 0xDF);
        WDT_STATUS = f81866ReadByte(F81866_WDT_PME_REG);
        f81866WriteByte(F81866_WDT_PME_REG, WDT_STATUS & 0xFE);
    }
}
```

```
Void aaeonSuperIOClose(){  
    aaeonioWritePortByte(F81866_INDEX, 0xaa);  
}
```

































Appendix

**B**

# I/O Information

## B.1 I/O Address Map

Input/output (IO)	
[00000000 - 0000001F]	Direct memory access controller
[00000000 - 00000CF7]	PCI bus
[00000010 - 0000001F]	Motherboard resources
[00000020 - 00000021]	Programmable interrupt controller
[00000022 - 0000003F]	Motherboard resources
[00000024 - 00000025]	Programmable interrupt controller
[00000028 - 00000029]	Programmable interrupt controller
[0000002C - 0000002D]	Programmable interrupt controller
[0000002E - 0000002F]	Motherboard resources
[00000030 - 00000031]	Programmable interrupt controller
[00000034 - 00000035]	Programmable interrupt controller
[00000038 - 00000039]	Programmable interrupt controller
[0000003C - 0000003D]	Programmable interrupt controller
[00000040 - 00000043]	System timer
[00000044 - 0000005F]	Motherboard resources
[0000004E - 0000004F]	Motherboard resources
[00000050 - 00000053]	System timer
[00000061 - 00000061]	Motherboard resources
[00000063 - 00000063]	Motherboard resources
[00000065 - 00000065]	Motherboard resources
[00000067 - 00000067]	Motherboard resources
[00000070 - 00000070]	Motherboard resources
[00000070 - 00000077]	System CMOS/real time clock
[00000072 - 0000007F]	Motherboard resources
[00000080 - 00000080]	Motherboard resources
[00000080 - 00000080]	Motherboard resources
[00000081 - 00000091]	Direct memory access controller
[00000084 - 00000086]	Motherboard resources
[00000088 - 00000088]	Motherboard resources
[0000008C - 0000008E]	Motherboard resources
[00000090 - 0000009F]	Motherboard resources
[00000092 - 00000092]	Motherboard resources
[00000093 - 0000009F]	Direct memory access controller
[000000A0 - 000000A1]	Programmable interrupt controller
[000000A2 - 000000BF]	Motherboard resources
[000000A4 - 000000A5]	Programmable interrupt controller
[000000A8 - 000000A9]	Programmable interrupt controller
[000000AC - 000000AD]	Programmable interrupt controller
[000000B0 - 000000B1]	Programmable interrupt controller
[000000B2 - 000000B3]	Motherboard resources
[000000B4 - 000000B5]	Programmable interrupt controller
[000000B8 - 000000B9]	Programmable interrupt controller
[000000BC - 000000BD]	Programmable interrupt controller
[000000C0 - 000000DF]	Direct memory access controller
[000000E0 - 000000EF]	Motherboard resources
[000000F0 - 000000F0]	Numeric data processor



















































	[000002E8 - 000002EF]	Communications Port (COM4)
	[000002F8 - 000002FF]	Communications Port (COM2)
	[000003B0 - 000003BB]	Intel(R) HD Graphics 4600
	[000003C0 - 000003DF]	Intel(R) HD Graphics 4600
	[000003E8 - 000003EF]	Communications Port (COM3)
	[000003F8 - 000003FF]	Communications Port (COM1)
	[000004D0 - 000004D1]	Motherboard resources
	[000004D0 - 000004D1]	Programmable interrupt controller
	[00000680 - 0000069F]	Motherboard resources
	[00000A00 - 00000A0F]	Motherboard resources
	[00000A10 - 00000A1F]	Motherboard resources
	[00000A20 - 00000A2F]	Motherboard resources
	[00000D00 - 0000FFFF]	PCI bus
	[0000164E - 0000164F]	Motherboard resources
	[00001800 - 000018FE]	Motherboard resources
	[00001854 - 00001857]	Motherboard resources
	[00001C00 - 00001CFE]	Motherboard resources
	[00001D00 - 00001DFE]	Motherboard resources
	[00001E00 - 00001EFE]	Motherboard resources
	[00001F00 - 00001FFE]	Motherboard resources
	[0000E000 - 0000FFFF]	Intel(R) 8 Series/C220 Series PCI Express Root Port #7 - 8C1C
	[0000F000 - 0000F03F]	Intel(R) HD Graphics 4600
	[0000F040 - 0000F05F]	Intel(R) 8 Series/C220 Series SMBus Controller - 8C22
	[0000F060 - 0000F07F]	Intel(R) 8 Series Chipset Family SATA AHCI Controller
	[0000F0A0 - 0000F0A3]	Intel(R) 8 Series Chipset Family SATA AHCI Controller
	[0000F0B0 - 0000F0B7]	Intel(R) 8 Series Chipset Family SATA AHCI Controller
	[0000F0C0 - 0000F0C3]	Intel(R) 8 Series Chipset Family SATA AHCI Controller
	[0000F0D0 - 0000F0D7]	Intel(R) 8 Series Chipset Family SATA AHCI Controller
	[0000F0E0 - 0000F0E7]	Intel(R) Active Management Technology - SOL (COM5)
	[0000FFFF - 0000FFFF]	Motherboard resources
	[0000FFFF - 0000FFFF]	Motherboard resources
	[0000FFFF - 0000FFFF]	Motherboard resources





































## B.2 Memory Address Map

Address Range	Device Name
[000A0000 - 000BFFFF]	Intel(R) HD Graphics 4600
[000A0000 - 000BFFFF]	PCI bus
[000D0000 - 000D3FFF]	PCI bus
[000D4000 - 000D7FFF]	PCI bus
[000D8000 - 000DBFFF]	PCI bus
[000DC000 - 000DFFFF]	PCI bus
[000E0000 - 000E3FFF]	PCI bus
[000E4000 - 000E7FFF]	PCI bus
[DF200000 - FEAFFFFF]	PCI bus
[E0000000 - EFFFFFFF]	Intel(R) HD Graphics 4600
[F6800000 - F6FFFFFF]	Intel(R) I211 Gigabit Network Connection #2
[F6800000 - F70FFFFFF]	Intel(R) 8 Series/C220 Series PCI Express Root Port #7 - 8C1C
[F7000000 - F7003FFF]	Intel(R) I211 Gigabit Network Connection #2
[F7400000 - F77FFFFFF]	Intel(R) HD Graphics 4600
[F7800000 - F781FFFF]	Intel(R) Ethernet Connection I217-LM
[F7820000 - F782FFFF]	Intel(R) USB 3.0 eXtensible Host Controller
[F7830000 - F7833FFF]	High Definition Audio Controller
[F7834000 - F7837FFF]	High Definition Audio Controller
[F7839000 - F78390FF]	Intel(R) 8 Series/C220 Series SMBus Controller - 8C22
[F783A000 - F783A7FF]	Intel(R) 8 Series Chipset Family SATA AHCI Controller
[F783B000 - F783B3FF]	Intel(R) 8 Series/C220 Series USB Enhanced Host Controller #1 - 8C26
[F783C000 - F783C3FF]	Intel(R) 8 Series/C220 Series USB Enhanced Host Controller #2 - 8C2D
[F783D000 - F783DFFF]	Intel(R) Ethernet Connection I217-LM
[F783E000 - F783EFFF]	Intel(R) Active Management Technology - SOL (COM5)
[F7840000 - F78400FF]	Intel(R) Management Engine Interface
[F7FEF000 - F7FEFFFF]	Motherboard resources
[F7FF0000 - F7FF0FFF]	Motherboard resources
[F8000000 - FBFFFFFF]	Motherboard resources
[FED00000 - FED003FF]	High precision event timer
[FED10000 - FED17FFF]	Motherboard resources
[FED18000 - FED18FFF]	Motherboard resources
[FED19000 - FED19FFF]	Motherboard resources
[FED1C000 - FED1FFFF]	Motherboard resources
[FED20000 - FED3FFFF]	Motherboard resources
[FED40000 - FED44FFF]	System board
[FED45000 - FED8FFFF]	Motherboard resources
[FED90000 - FED93FFF]	Motherboard resources
[FEE00000 - FEEFFFFFF]	Motherboard resources
[FF000000 - FFFFFFFF]	Intel(R) 82802 Firmware Hub Device
[FF000000 - FFFFFFFF]	Motherboard resources

## B.3 IRQ Mapping Chart

Interrupt request (IRQ)	Description
(ISA) 0x00000000 (00)	System timer
(ISA) 0x00000003 (03)	Communications Port (COM2)
(ISA) 0x00000004 (04)	Communications Port (COM1)
(ISA) 0x00000008 (08)	System CMOS/real time clock
(ISA) 0x0000000A (10)	Communications Port (COM3)
(ISA) 0x0000000B (11)	Communications Port (COM4)
(ISA) 0x0000000D (13)	Numeric data processor
(ISA) 0x00000051 (81)	Microsoft ACPI-Compliant System
(ISA) 0x00000052 (82)	Microsoft ACPI-Compliant System
(ISA) 0x00000053 (83)	Microsoft ACPI-Compliant System
(ISA) 0x00000054 (84)	Microsoft ACPI-Compliant System
(ISA) 0x00000055 (85)	Microsoft ACPI-Compliant System
(ISA) 0x00000056 (86)	Microsoft ACPI-Compliant System
(ISA) 0x00000057 (87)	Microsoft ACPI-Compliant System
(ISA) 0x00000058 (88)	Microsoft ACPI-Compliant System
(ISA) 0x00000059 (89)	Microsoft ACPI-Compliant System
(ISA) 0x0000005A (90)	Microsoft ACPI-Compliant System
(ISA) 0x0000005B (91)	Microsoft ACPI-Compliant System
(ISA) 0x0000005C (92)	Microsoft ACPI-Compliant System
(ISA) 0x0000005D (93)	Microsoft ACPI-Compliant System
(ISA) 0x0000005E (94)	Microsoft ACPI-Compliant System
(ISA) 0x0000005F (95)	Microsoft ACPI-Compliant System
(ISA) 0x00000060 (96)	Microsoft ACPI-Compliant System
(ISA) 0x00000061 (97)	Microsoft ACPI-Compliant System
(ISA) 0x00000062 (98)	Microsoft ACPI-Compliant System
(ISA) 0x00000063 (99)	Microsoft ACPI-Compliant System
(ISA) 0x00000064 (100)	Microsoft ACPI-Compliant System
(ISA) 0x00000065 (101)	Microsoft ACPI-Compliant System
(ISA) 0x00000066 (102)	Microsoft ACPI-Compliant System
(ISA) 0x00000067 (103)	Microsoft ACPI-Compliant System
(ISA) 0x00000068 (104)	Microsoft ACPI-Compliant System
(ISA) 0x00000069 (105)	Microsoft ACPI-Compliant System
(ISA) 0x0000006A (106)	Microsoft ACPI-Compliant System
(ISA) 0x0000006B (107)	Microsoft ACPI-Compliant System
(ISA) 0x0000006C (108)	Microsoft ACPI-Compliant System
(ISA) 0x0000006D (109)	Microsoft ACPI-Compliant System
(ISA) 0x0000006E (110)	Microsoft ACPI-Compliant System
(ISA) 0x0000006F (111)	Microsoft ACPI-Compliant System
(ISA) 0x00000070 (112)	Microsoft ACPI-Compliant System
(ISA) 0x00000071 (113)	Microsoft ACPI-Compliant System
(ISA) 0x00000072 (114)	Microsoft ACPI-Compliant System
(ISA) 0x00000073 (115)	Microsoft ACPI-Compliant System
(ISA) 0x00000074 (116)	Microsoft ACPI-Compliant System
(ISA) 0x00000075 (117)	Microsoft ACPI-Compliant System
(ISA) 0x00000076 (118)	Microsoft ACPI-Compliant System
(ISA) 0x00000077 (119)	Microsoft ACPI-Compliant System
(ISA) 0x00000078 (120)	Microsoft ACPI-Compliant System

 (ISA) 0x00000079 (121)	Microsoft ACPI-Compliant System
 (ISA) 0x0000007A (122)	Microsoft ACPI-Compliant System
 (ISA) 0x0000007B (123)	Microsoft ACPI-Compliant System
 (ISA) 0x0000007C (124)	Microsoft ACPI-Compliant System
 (ISA) 0x0000007D (125)	Microsoft ACPI-Compliant System
 (ISA) 0x0000007E (126)	Microsoft ACPI-Compliant System
 (ISA) 0x0000007F (127)	Microsoft ACPI-Compliant System
 (ISA) 0x00000080 (128)	Microsoft ACPI-Compliant System
 (ISA) 0x00000081 (129)	Microsoft ACPI-Compliant System
 (ISA) 0x00000082 (130)	Microsoft ACPI-Compliant System
 (ISA) 0x00000083 (131)	Microsoft ACPI-Compliant System
 (ISA) 0x00000084 (132)	Microsoft ACPI-Compliant System
 (ISA) 0x00000085 (133)	Microsoft ACPI-Compliant System
 (ISA) 0x00000086 (134)	Microsoft ACPI-Compliant System
 (ISA) 0x00000087 (135)	Microsoft ACPI-Compliant System
 (ISA) 0x00000088 (136)	Microsoft ACPI-Compliant System
 (ISA) 0x00000089 (137)	Microsoft ACPI-Compliant System
 (ISA) 0x0000008A (138)	Microsoft ACPI-Compliant System
 (ISA) 0x0000008B (139)	Microsoft ACPI-Compliant System
 (ISA) 0x0000008C (140)	Microsoft ACPI-Compliant System
 (ISA) 0x0000008D (141)	Microsoft ACPI-Compliant System
 (ISA) 0x0000008E (142)	Microsoft ACPI-Compliant System
 (ISA) 0x0000008F (143)	Microsoft ACPI-Compliant System
 (ISA) 0x00000090 (144)	Microsoft ACPI-Compliant System
 (ISA) 0x00000091 (145)	Microsoft ACPI-Compliant System
 (ISA) 0x00000092 (146)	Microsoft ACPI-Compliant System
 (ISA) 0x00000093 (147)	Microsoft ACPI-Compliant System
 (ISA) 0x00000094 (148)	Microsoft ACPI-Compliant System
 (ISA) 0x00000095 (149)	Microsoft ACPI-Compliant System
 (ISA) 0x00000096 (150)	Microsoft ACPI-Compliant System
 (ISA) 0x00000097 (151)	Microsoft ACPI-Compliant System
 (ISA) 0x00000098 (152)	Microsoft ACPI-Compliant System
 (ISA) 0x00000099 (153)	Microsoft ACPI-Compliant System
 (ISA) 0x0000009A (154)	Microsoft ACPI-Compliant System
 (ISA) 0x0000009B (155)	Microsoft ACPI-Compliant System
 (ISA) 0x0000009C (156)	Microsoft ACPI-Compliant System
 (ISA) 0x0000009D (157)	Microsoft ACPI-Compliant System
 (ISA) 0x0000009E (158)	Microsoft ACPI-Compliant System
 (ISA) 0x0000009F (159)	Microsoft ACPI-Compliant System
 (ISA) 0x000000A0 (160)	Microsoft ACPI-Compliant System
 (ISA) 0x000000A1 (161)	Microsoft ACPI-Compliant System
 (ISA) 0x000000A2 (162)	Microsoft ACPI-Compliant System
 (ISA) 0x000000A3 (163)	Microsoft ACPI-Compliant System
 (ISA) 0x000000A4 (164)	Microsoft ACPI-Compliant System
 (ISA) 0x000000A5 (165)	Microsoft ACPI-Compliant System
 (ISA) 0x000000A6 (166)	Microsoft ACPI-Compliant System
 (ISA) 0x000000A7 (167)	Microsoft ACPI-Compliant System
 (ISA) 0x000000A8 (168)	Microsoft ACPI-Compliant System
 (ISA) 0x000000A9 (169)	Microsoft ACPI-Compliant System
 (ISA) 0x000000AA (170)	Microsoft ACPI-Compliant System

	(ISA) 0x000000AB (171)	Microsoft ACPI-Compliant System
	(ISA) 0x000000AC (172)	Microsoft ACPI-Compliant System
	(ISA) 0x000000AD (173)	Microsoft ACPI-Compliant System
	(ISA) 0x000000AE (174)	Microsoft ACPI-Compliant System
	(ISA) 0x000000AF (175)	Microsoft ACPI-Compliant System
	(ISA) 0x000000B0 (176)	Microsoft ACPI-Compliant System
	(ISA) 0x000000B1 (177)	Microsoft ACPI-Compliant System
	(ISA) 0x000000B2 (178)	Microsoft ACPI-Compliant System
	(ISA) 0x000000B3 (179)	Microsoft ACPI-Compliant System
	(ISA) 0x000000B4 (180)	Microsoft ACPI-Compliant System
	(ISA) 0x000000B5 (181)	Microsoft ACPI-Compliant System
	(ISA) 0x000000B6 (182)	Microsoft ACPI-Compliant System
	(ISA) 0x000000B7 (183)	Microsoft ACPI-Compliant System
	(ISA) 0x000000B8 (184)	Microsoft ACPI-Compliant System
	(ISA) 0x000000B9 (185)	Microsoft ACPI-Compliant System
	(ISA) 0x000000BA (186)	Microsoft ACPI-Compliant System
	(ISA) 0x000000BB (187)	Microsoft ACPI-Compliant System
	(ISA) 0x000000BC (188)	Microsoft ACPI-Compliant System
	(ISA) 0x000000BD (189)	Microsoft ACPI-Compliant System
	(ISA) 0x000000BE (190)	Microsoft ACPI-Compliant System
	(PCI) 0x00000005 (05)	Intel(R) 8 Series/C220 Series SMBus Controller - 8C22
	(PCI) 0x00000010 (16)	High Definition Audio Controller
	(PCI) 0x00000010 (16)	Intel(R) 8 Series/C220 Series USB Enhanced Host Controller #2 - 8C2D
	(PCI) 0x00000010 (16)	Intel(R) Management Engine Interface
	(PCI) 0x00000013 (19)	Intel(R) Active Management Technology - SOL (COM5)
	(PCI) 0x00000016 (22)	High Definition Audio Controller
	(PCI) 0x00000017 (23)	Intel(R) 8 Series/C220 Series USB Enhanced Host Controller #1 - 8C26
	(PCI) 0xFFFFFFFF5 (-11)	Intel(R) I211 Gigabit Network Connection #2
	(PCI) 0xFFFFFFFF6 (-10)	Intel(R) I211 Gigabit Network Connection #2
	(PCI) 0xFFFFFFFF7 (-9)	Intel(R) I211 Gigabit Network Connection #2
	(PCI) 0xFFFFFFFF8 (-8)	Intel(R) I211 Gigabit Network Connection #2
	(PCI) 0xFFFFFFFF9 (-7)	Intel(R) Ethernet Connection I217-LM
	(PCI) 0xFFFFFFFFFA (-6)	Intel(R) USB 3.0 eXtensible Host Controller
	(PCI) 0xFFFFFFFFFB (-5)	Intel(R) HD Graphics 4600
	(PCI) 0xFFFFFFFFFC (-4)	Intel(R) 8 Series Chipset Family SATA AHCI Controller
	(PCI) 0xFFFFFFFFFD (-3)	Intel(R) 8 Series/C220 Series PCI Express Root Port #7 - 8C1C
	(PCI) 0xFFFFFFFFFE (-2)	Intel(R) 8 Series/C220 Series PCI Express Root Port #1 - 8C10

## B.4 DMA Channel Assignments

---

- Direct memory access (DMA)
  - 4 Direct memory access controller

Appendix

C

# Mating Connector

## C.1 List of Mating Connectors and Cables

The table notes mating connectors and available cables.

Connector Label	Function	Mating Connector		Available Cable	Cable P/N
		Vendor	Model no		
CN1	External +5VSB Power Input and PS_ON#	JST	XHP-3	ATX Cable	170220020B
CN2	2 <sup>nd</sup> LVDS Inverter	JST	PHR-5	Inverter Cable	1705050153
CN3	+5V Output for SATA HDD using	JST	PHR-2	2 Pins For SATA Power	1702150155
CN4	+5VSB Output w/ SMBus	JST	PHR-6	ATX External 5VSB Cable	External AUX Power and PS_ON#
CN5	CPU Fan Connector	Molex	22-01-2035	N/A	N/A
CN6	SATA Port 2	Molex	887505318	SATA Cable	1709070500
CN7	SATA Port 1	Molex	887505318	SATA Cable	1709070500
CN8	External 12V Input	Molex	19211-0003	Power Cable	170204010R
CN9	Digital I/O	Molex	51110-1050	N/A	N/A
CN10	1 <sup>st</sup> LVDS Inverter	JST	PHR-5	Inverter Cable	1705050153

CN12	USB 2.0 Port #3	Molex	51021-0500	USB Wafer Cable	1700050207
CN13	USB 2.0 Port #4	Molex	51021-0500	USB Wafer Cable	1700050207
CN14	1 <sup>st</sup> LVDS (Single channel 18/24bit)	HIROSE	DF13-30DS- 1.25C	N/A	N/A
CN15	2 <sup>nd</sup> LVDS (Dual channel 18/24bit)	HIROSE	DF13-30DS- 1.25C	N/A	N/A
CN16	USB 2.0 Port #5	Molex	51021-0500	USB Wafer Cable	1700050207
CN17	USB 2.0 Port #6	Molex	51021-0500	USB Wafer Cable	1700050207
CN18	USB 2.0 Port #8	Molex	51021-0500	USB Wafer Cable	1700050207
CN19	USB 2.0 Port #7	Molex	51021-0500	USB Wafer Cable	1700050207
CN20	Touch Screen	JST	SHR-9V-S-B	N/A	N/A
CN21	COM Port #4	Molex	51021-0900	UART Wafer Cable	1701090150
CN22	COM Port #3	Molex	51021-0900	UART Wafer Cable	1701090150
CN23	LPC Expansion I/F	JST	SHR-12V-S- B	AAEON LPC Cable	1703120130

CN24	COM Port #2	Molex	51021-0900	UART Wafer Cable	1701090150
CN25	PS/2 Keyboard & Mouse	JST	PHDR-06VS	KB/MS Cable	1700060152
CN26	Stereo-R Channel	Molex	51021-0200	N/A	N/A
CN27	Stereo-L Channel	Molex	51021-0200	N/A	N/A
CN29	1 <sup>st</sup> RJ-45 Ethernet	Molex	90075-0141	N/A	N/A
CN30	2 <sup>nd</sup> RJ-45 Ethernet	Molex	90075-0141	N/A	N/A
CN32	Audio Line In/Out and MIC Connector	Molex	51021-1000	Audio Cable	1709100254
BAT1	External RTC Connector	Molex	51021-0200	Battery Cable	175011901C

Appendix

**D**

# **Electrical Specifications for I/O Ports**

### D.1 Electrical Specifications for I/O Ports

I/O	Reference	Signal Name	Rate Output
LVDS Port 1 Inverter / Backlight Connector	CN10	VDD	+5V/2A or +12V/2A
LVDS Port 2 Inverter / Backlight Connector	CN2	VDD	+5V/2A or +12V/2A
USB 3.0 Port 1 & 2	CN31	+5VSB	+5VSB/1A (per channel)
USB 2.0 Port 3	CN12	+5VSB	
USB 2.0 Port 4	CN13	+5VSB	
USB 2.0 Port 5	CN16	+5VSB	+5VSB/0.5A
USB 2.0 Port 6	CN17	+5VSB	(per channel)
USB 2.0 Port 7	CN19	+5VSB	
USB 2.0 Port 8	CN18	+5VSB	
Audio I/O Port	CN32	+5V	+5V/0.5A
LVDS Port 1	CN14	VCC	+3.3V/2A or +5V/2A
LVDS Port 2	CN15	VCC	+3.3V/2A or +5V/2A

**SubCompact Board****GENE-QM87**

COM Port 2	CN24	+5V/+12V	+5V/1A or +12V/1A
Digital IO Port	CN9	D0~D7	+5V/(Open drain)
PS/2 Keyboard/Mouse Combo Port	CN25	+5VSB	+5VSB/1A
CPU FAN	CN5	VDD	+12V/0.5A
+5V Output for SATA HDD	CN3	+5V	+5V/1A
VGA / DVI Ports (depend on hardware configuration)	CN35	VGA: +5V DVI : +5V	+5V/1A (reserved) +5V/0.5A
CFast Slot	CFD1	+3.3V	+3.3V/0.5A
Mini-Card Slot	PCIE1	+3.3VSB +1.5V	+3.3V/1.1A +1.5V/0.375A
LPC Port	CN23	+3.3V	+3.3V/0.5A

Appendix

**E**

**DIO**

## E.1 The related register for configuring DIO is list as follows:

7.1.2 Logic Device Number Register (LDN) — Index 07h

Bit	Name	R/W	Reset	Default	Description
7-0	LDN	R/W	LRESET#	00h	00h: Select FDC device configuration registers. 03h: Select Parallel Port device configuration registers. 04h: Select Hardware Monitor device configuration registers. 05h: Select KBC device configuration registers. 06h: Select GPIO device configuration registers. 07h: Select WDT device configuration registers. 0Ah: Select PME, ACPI and ERP device configuration registers. 10h: Select UART1 device configuration registers. 11h: Select UART2 device configuration registers. 12h: Select UART3 device configuration registers. 13h: Select UART4 device configuration registers. 14h: Select UART5 device configuration registers. 15h: Select UART6 device configuration registers. Otherwise: Reserved.

GPIO5 Output Enable Register — Index A0h

Bit	Name	R/W	Reset	Default	Description
7	GPIO57_OE	R/W	LRESET#	0	0: GPIO57 is in input mode. 1: GPIO57 is in output mode.
6	GPIO56_OE	R/W	LRESET#	0	0: GPIO56 is in input mode. 1: GPIO56 is in output mode.
5	GPIO55_OE	R/W	LRESET#	0	0: GPIO55 is in input mode. 1: GPIO55 is in output mode.
4	GPIO54_OE	R/W	LRESET#	0	0: GPIO54 is in input mode. 1: GPIO54 is in output mode.
3	GPIO53_OE	R/W	LRESET#	0	0: GPIO53 is in input mode. 1: GPIO53 is in output mode.
2	GPIO52_OE	R/W	LRESET#	0	0: GPIO52 is in input mode. 1: GPIO52 is in output mode.
1	GPIO51_OE	R/W	LRESET#	0	0: GPIO51 is in input mode. 1: GPIO51 is in output mode.
0	GPIO50_OE	R/W	LRESET#	0	0: GPIO50 is in input mode. 1: GPIO50 is in output mode.

GPIO5 Output Data Register — Index A1h (This byte could be also written by base address + 5)

Bit	Name	R/W	Reset	Default	Description
7	GPIO57_DATA	R/W	LRESET#	1	0: GPIO57 outputs 0 when in output mode. 1: GPIO57 outputs 1 when in output mode.
6	GPIO56_DATA	R/W	LRESET#	1	0: GPIO56 outputs 0 when in output mode. 1: GPIO56 outputs 1 when in output mode.
5	GPIO55_DATA	R/W	LRESET#	1	0: GPIO55 outputs 0 when in output mode. 1: GPIO55 outputs 1 when in output mode.
4	GPIO54_DATA	R/W	LRESET#	1	0: GPIO54 outputs 0 when in output mode. 1: GPIO54 outputs 1 when in output mode.
3	GPIO53_DATA	R/W	LRESET#	1	0: GPIO53 outputs 0 when in output mode. 1: GPIO53 outputs 1 when in output mode.
2	GPIO52_DATA	R/W	LRESET#	1	0: GPIO52 outputs 0 when in output mode. 1: GPIO52 outputs 1 when in output mode.
1	GPIO51_DATA	R/W	LRESET#	1	0: GPIO51 outputs 0 when in output mode. 1: GPIO51 outputs 1 when in output mode.
0	GPIO50_DATA	R/W	LRESET#	1	0: GPIO50 outputs 0 when in output mode. 1: GPIO50 outputs 1 when in output mode.

GPIO5 Pin Status Register — Index A2h (This byte could be also read by base address + 5)

Bit	Name	R/W	Reset	Default	Description
7	GPIO57_ST	R	-	-	The pin status of GPIO57/WGATE#/DSR6#.
6	GPIO56_ST	R	-	-	The pin status of GPIO56/HDSEL#/DTR6#.
5	GPIO55_ST	R	-	-	The pin status of GPIO55/STEP#/CTS6#.
4	GPIO54_ST	R	-	-	The pin status of GPIO54/DIR#/R16#.
3	GPIO53_ST	R	-	-	The pin status of GPIO53/WDATA#/DCD6#.
2	GPIO52_ST	R	-	-	The pin status of GPIO52/DRVA#/SOUT6.
1	GPIO51_ST	R	-	-	The pin status of GPIO51/MOA#/SIN6.
0	GPIO50_ST	R	-	-	The pin status of GPIO50/DENSEL#/RTS6#.

The following is a sample code for 4 in 4 out (2 low 2 high)

```
Outportb(0x2E,0x87); //enter configuration
```

```
Outportb(0x2E,0x87);
```

```
Outportb(0x2E,0x07); //set LDN
```

```
Outportb(0x2F,0x06);
```

Outportb(0x2E,0xA0); //GPIO set 5 register

Outportb(0x2F,0xF0);

Outportb(0x2E,0xA1); //GPIO output data register

Outportb(0x2F,0x30);

Outportb(0x2E,0xAA); //exit configuration