

# VMIVME-1182 Specifications

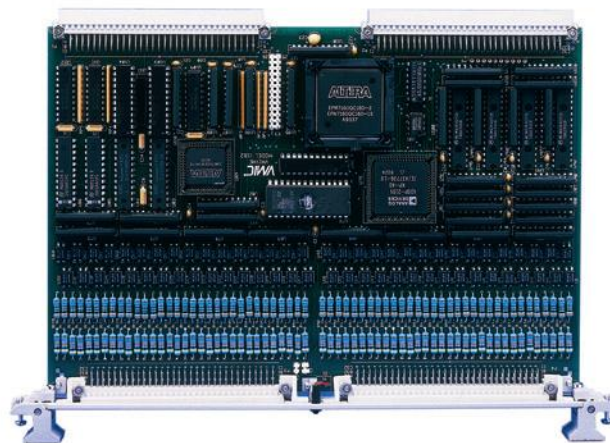

## 64-Channel Isolated Digital Input Board with Multifunctional Intelligent Controller

### Features:

- 64 optically isolated inputs
- Multifunctions available per channel
  - Change-of-State (COS)
  - Sequence of Events (SOEs)
  - Pulse accumulation
  - Programmable debounce times
  - Time tagging
- 5 to 250VDC or 4 to 240VAC
- 1,500VDC or 1,100VRMS channel-to-channel and channel-to-VME isolation
- Pulse accumulation (0 to 65,535 pulses)
- SOEs monitoring on channel-by-channel basis
- Debounce times, software controlled on channel-by-channel basis
- 1.0ms measurement interval
- COS functions, software controlled on a channel-by-channel basis
- COS selections: disabled, rising edge (low-to-high transition), falling edge (high-to-low transition) or any edge
- Short or standard, supervisory, nonprivileged or either access
- Interrupt level is user selected
- UIOC® compatible
- Complies with ANSI/IEEE STD C37.90.1-1989 surge protection when used with companion suppression panel (for example, VMIVME-3459)

### Applications:

- Data acquisition systems
- Nuclear power plant monitoring
- Control systems



Ordering Options						
May 30, 2007 800-001182-000 G	A	B	C	D	E	F
VMIVME-1182	-	0		0	0	

**A = 0 (Option reserved for future use)**

**B = Input Voltage Range\***

- 0 = 5VDC, 4VAC
- 1 = 12VDC, 10VAC
- 2 = 24VDC, 18VAC
- 3 = 28VDC, 20VAC
- 4 = 48VDC, 45VAC
- 5 = 60VDC, 55VAC
- 6 = 125VDC, 110VAC
- 7 = 250VDC, 240VAC

**C = Input Configuration**

- 0 = Voltage Sensing
- 1 = Contact Sensing

**DE = 0 (Option reserved for future use)**

**F = Special Sales Order**

- 0 = Standard VME front panel without conformal coating
- 1 = Reserved
- 2 = Standard VME front panel with conformal coating
- 3 = Reserved
- 4 = Reserved
- 5 = Reserved

Connector Data	
Discrete Wire Input Connector Data	

Mating Connector	AMP No. 925486-1
Female Crimp Contacts*	AMP No. 530151-6
Connector Shell Housing	Harting No. 09 03 096 0501
PC Board Connector	Panduit No. 120-964-033A

\*An AMP crimp tool part number is 90301-2

Note
------

\*DC or AC is software selectable.

For Ordering Information, Call: 1-800-322-3616 or 1-256-880-0444 • FAX (256) 882-0859 Email: <a href="mailto:info.embeddedsystems@gefanuc.com">info.embeddedsystems@gefanuc.com</a> Web Address: <a href="http://www.gefanucembedded.com">www.gefanucembedded.com</a> Copyright © 2007 by GE Fanuc Embedded Systems Specifications subject to change without notice.
---

## Functional Characteristics

**Introduction:** The VMIVME-1182 provides 64 digital inputs with which COS can be detected, time tagged and counted. An onboard buffer can be programmed to store the COS information with a time-tag such that SOEs can be analyzed. A pulse accumulator is provided to count the COSs. The VMIVME-1182 can also be programmed to issue an interrupt when a COS is detected. All COS detection is on a per-channel basis effectively creating 64 pulse accumulators.

The SOE memory is allocated into two buffers. The system host can be processing one buffer while the other buffer is being loaded with new event data.

Each input is optically isolated with input voltage options up to 250VDC. Inputs may also be configured for contact sensing. A programmable debouncer is provided for each input to reject spurious input pulses.

**Change-Of-State (COS) Timing:** The VMIVME-1182 latches the input signals every millisecond. After a programmable debounce time, if a valid COS is detected, it is time tagged by the millisecond timer and stored for processing. The debounce time can be from 1.25ms to 1.024s. Therefore, the minimum pulse time that can be reliably detected is 2ms.

If the VMIVME-1182 is programmed to detect COS on both rising and falling edges, the minimum time in each state is 2ms. Thus, 4ms is the minimum period of a continuous input signal.

Each input channel is independent and is processed separately, so activity on one channel has no effect on other channels. A COS on one channel can be detected and stored while the debouncer is timing on another channel. Since all inputs are latched simultaneously every millisecond and they are processed separately, there can be a minimum of 1ms between events that occur on different channels.

**Change-Of-State Detection:** State change detection can be programmed for rising edge (low-to-high transition), falling edge (high-to-low transition), or both rising and falling edges. In addition, COS detection can generate an interrupt or be disabled.

**Time Tagging:** Each Change-of-State event can be time tagged with a timer value of 0 to 65s and is initialized or preset by writing to the time tag register.

The timer value is updated every millisecond. When the timer value has reached its maximum value, it rolls over to 0 and notifies the host of a time tag rollover via a bit in the Control Register, or if desired, an interrupt may be issued.

**Sequence-Of-Events:** Each change-of-state (depending on change select options) can be time-tagged in the sequence-of-event buffer. The SOE buffer collects the channel ID, and the time (time tag register) in which the state changed. This buffer can contain 3,000 events. When the host is accessing the SOE buffer, the VMIVME-1182 will continue to monitor the inputs and store events in a mirrored SOE buffer. The additional buffer also provides 3,000 events of storage. This allows the user the ability to process the SOE data (without time constraint problems) and not lose any event data. The SOE logic can provide an interrupt to the host at the End-of-Buffer or an interrupt at a count provided by the user (programmable).

**Pulse Accumulation:** Each channel has an associated Pulse Accumulation Count (PAC) Register. These registers have values which represent the number of pulses which have been detected at the field input. A pulse is edge-recognized by either a state change from a 0 to 1 or a state change from 1 to 0. The user will be notified when the count in the PAC Register has reached its maximum value of 65,535 pulses. This condition is indicated by a flag set in the Control Register, or if desired, an interrupt may also be issued.

**Inputs:** The VMIVME-1182 can be ordered in the Voltage Sensing option or the Contact Sensing option. The input configurations for each of these options are shown in Figure 2.

The Contact Sensing option is provided with pull-up resistors to the wetting voltage pins. The Voltage sourcing option does not provide pull-ups.

There are eight wetting voltage input pins applied on byte boundaries. The inputs are provided on the P2 connector. An additional feature is the ability to drive the wetting input via channel 32 of the P3 connector. Through the use of jumpers (see Figure 3), channel 32 can be sacrificed as a channel and its HIGH input used to supply a wetting voltage to all channels. The LOW side of channel 32 can be jumpered to acquire Digital ground from the VMIVME-1182.

Table 1. Electrical Specifications for Inputs

Input Voltage (VDC)	Threshold High (V)	Threshold Low (V)	Contact Sensing		Voltage Sensing (mA)
			Open Circuit Voltage (V) ±8%	Contact Current (mA) ±15%	Source Current @ V <sub>INPUT</sub> ±15%
5	3.4	1.7	4.4	6.7	1.0
12	8.2	3.3	11.0	8.0	0.9
24	17	6.0	21.3	6.0	0.8
28	17	6.0	24.8	7.0	0.9
48	33	11.0	41.3	4.8	0.8
60	41.5	14.0	53.5	6.0	0.7
125	85	30.0	87	2.7	0.7
250	189	66.0	157	1.6	0.9

**Interchannel Crosstalk Rejection:** 80dB minimum at 1kHz

**Common-Mode Rejection:** 80dB minimum DC to 60Hz

**Isolation:** 1,500VDC or 1,100VRMS field-to-bus, channel-to-channel for voltage sensing

1,500VDC or 1,100VRMS field-to-bus, byte-to-byte for contact sensing when wetting voltage applied at P2.

**VME Compliance:** This board complies with the VMEbus specification (ANSI/IEEE STD 1014-1987 IEC 821 and 297) with the following mnemonics:

Addressing Mode	Responding Address Modifiers
A24	\$39 (Standard nonprivileged data access) or \$3D (Standard supervisory data access)
A16	\$29 (Short nonprivileged I/O access) or \$2D (Short supervisory I/O access)
Data Access	D16, D08(E0)
Interrupts	One, any level, ROAK

**Board Address:** The base VME address is set by configuration of a jumper field. A jumper exists for each of the addresses A23 through A14; thus, the address space occupied by this board is 8 Kwords.

**VME Access:** Address modifier bits are jumper selected and decoded to support nonprivileged, supervisory, and either nonprivileged or supervisory board accesses.

**Self-Test:** Self-test is run automatically after a system reset and can also be run by activating the Test Mode bit in the CSR. A pass/fail value is stored in the Control Register space. The LED remains illuminated regardless of the pass/fail status of the self-test. The self-test is primarily an integrity check of the microcontroller and the onboard memory.

**System Reset:** After a system reset, the following default conditions exist:

- Input transfers with 1ms debounce
- LED illuminated
- Test Mode enabled

**Front Panel Status LED:** This indicator is illuminated after a system reset. The LED can also be turned ON and OFF under software control.

**Interrupts:** An interrupt can be issued on any level (software selectable) and a single byte vector will be placed on the bus when acknowledged. There is one ROAK interrupt for the board. The following conditions can initiate the interrupt:

- COS on any of the 64 channels
- Time-Tag Rollover
- Pulse Accumulation Rollover on any of the 64 channels
- SOE, End-of-buffer
- SOE buffer count equal to programmable maximum count provided by user

Each of these interrupt conditions may be enabled or disabled by the host.

## Physical/Environmental Specifications

**Dimensions:** Standard VME double height board

Height	9.2 in. (233.4mm)
Depth	6.3 in. (160mm)
Thickness	0.8 in. (20.3mm)

**Power Requirements:** 2.0A (typical) at 5V plus any power dissipated in pull-up resistors

**Airflow:** Forced air cooling required

### Temperature:

Operating: 0 to +65° C  
Storage: -25 to +85° C

### Altitude:

Operating: 0 - 10,000 ft (3,048m)

### Humidity:

Operating: relative humidity 20% to 80%, noncondensing

**Weight (Mass):** 0.7kg maximum

## Trademarks

All registered trademarks are the property of their respective owners.

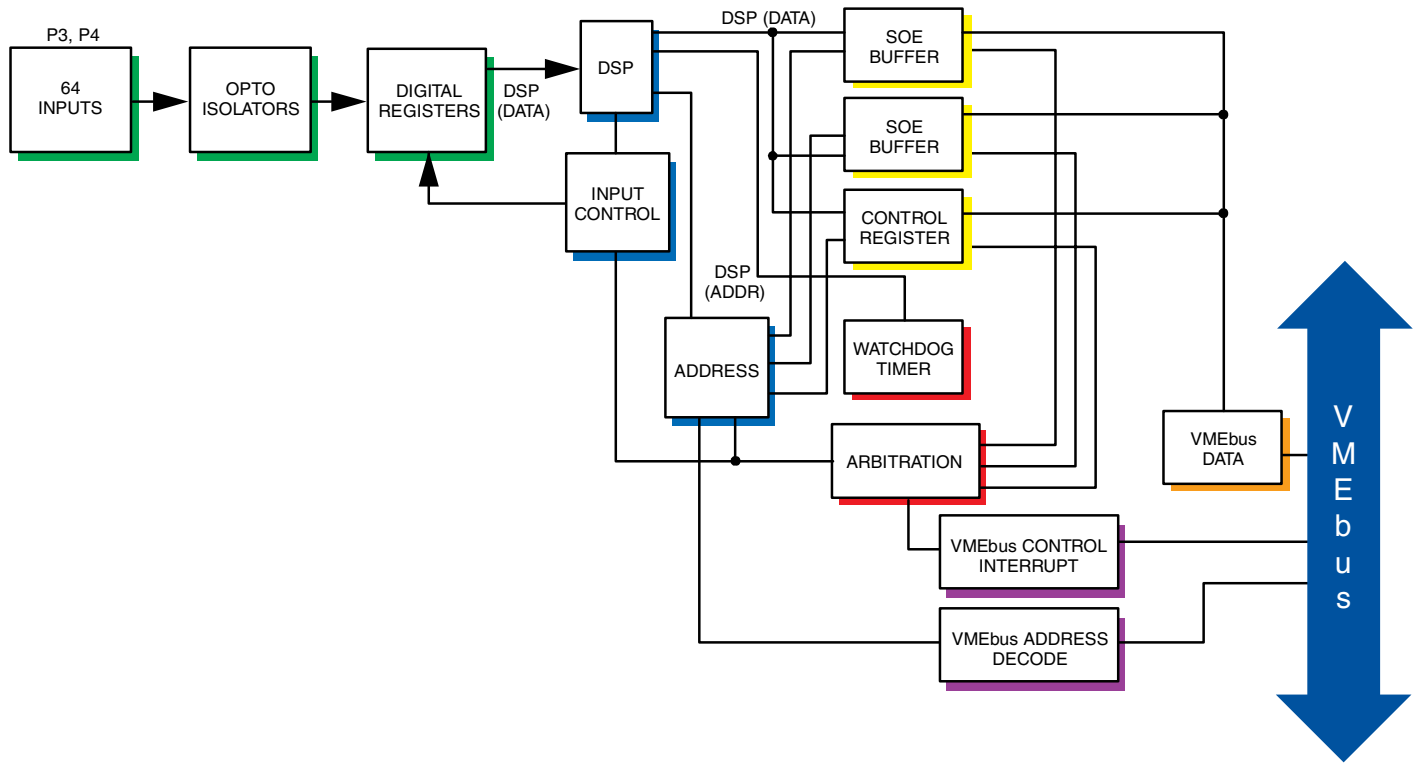

Figure 1. VMIVME-1182 Functional Block Diagram

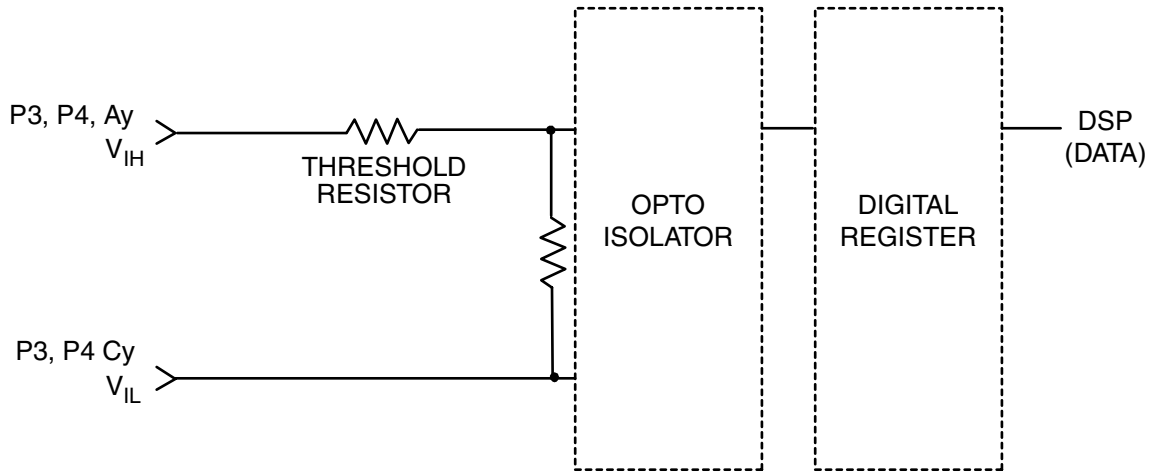

Figure 2a. User Input Connection Circuit (Voltage Sensing)

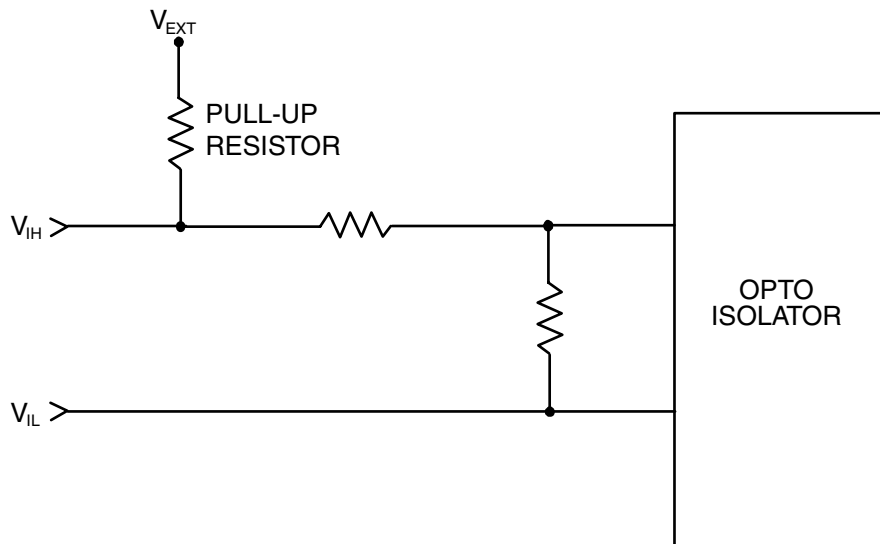

Figure 2b. Contact Sensing

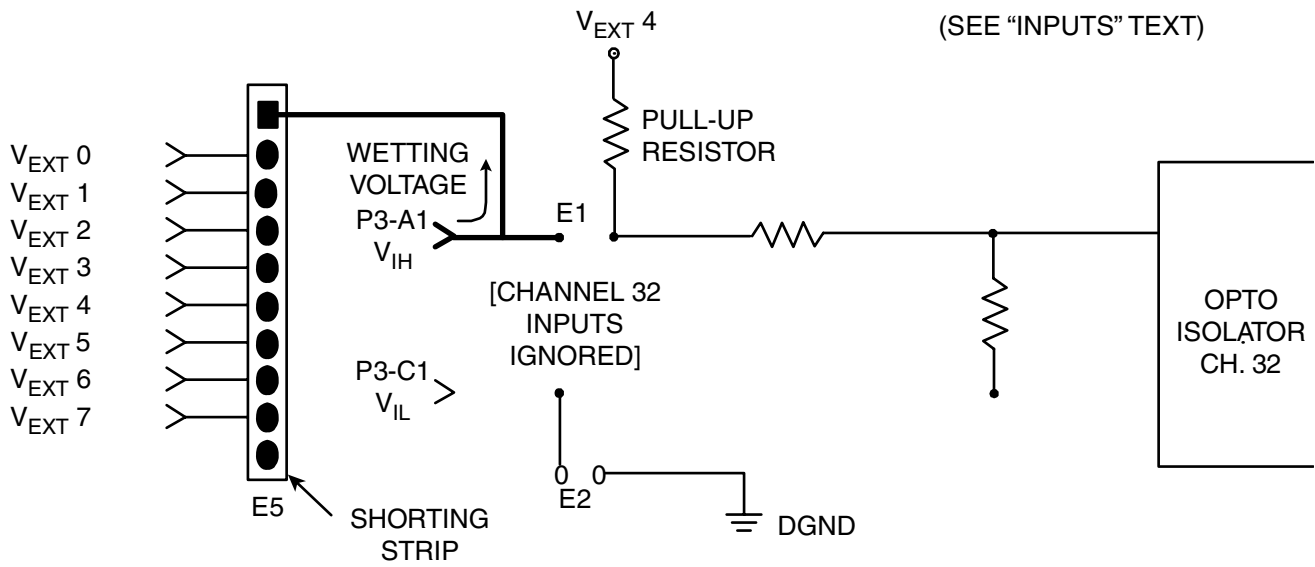

Figure 3. P3 Wetting Voltage Input



GE Fanuc Embedded Systems Information Centers

- Americas:  
 Huntsville, AL 1 800 322-3616  
 1 (256) 880-0444  
 Camarillo, CA 1 (805) 987-9300  
 Greenville, SC 1 (864) 627-8800  
 Richardson, TX 1 (972) 671-1972
- Europe, Middle East and Africa:  
 Edinburgh, UK 44 (131) 561-3520  
 Paris, France 33 (1) 4324 6007

Additional Resources

For more information, please visit the GE Fanuc Embedded Systems web site at: [www.gefanucembedded.com](http://www.gefanucembedded.com)