



PB-SIO4

Quad Serial Port Piggyback RS232

Manual ID 19957, Rev. Index 0300
Sep 99



The product described in this manual is in compliance with all applied CE standards.

This page was intentionally left blank.



Preface

<i>Revision History</i>	0 - 4
<i>Trademarks</i>	0 - 4
<i>Explanation of Symbols</i>	0 - 5
<i>For Your Safety</i>	0 - 6
<i>High Voltage Safety Instructions</i>	0 - 6
<i>Special Handling and Unpacking Instructions</i>	0 - 6
<i>General Instructions on Usage</i>	0 - 7
<i>Two Years Warranty</i>	0 - 8
<i>Table of Contents</i>	0 - 9



Revision History

Revision History			
Manual/Product Title:		PB-SIO4	
Manual ID Number:		19957	
Rev. Index	Brief Description of Changes	Board Index	Date of Issue
1	Initial Issue		Sep 1991
2	Title Page updated		Sep 1997
0300	Complete revision of manual	02	Sep 1999

This document contains information proprietary of *PEP Modular Computers*. It may not be copied or transmitted by any means, disclosed to others or stored in any retrieval system or media, without the prior written consent of *PEP Modular Computers GmbH* or one of its authorized agents.

The information contained in this document is, to the best of our knowledge, entirely correct. However, *PEP Modular Computers* cannot accept liability for any inaccuracies, or the consequences thereof, nor for any liability arising from the use or application of any circuit, product, or example shown in this document.

PEP Modular Computers reserve the right to change, modify, or improve this document or the product described herein, as seen fit by *PEP Modular Computers* without further notice.

Trademarks

PEP Modular Computers, the *PEP* logo and “CXM” are trade marks owned by *PEP Modular Computers GmbH*, Kaufbeuren (Germany). In addition, this document may include names, company logos and trademarks, which are registered trademarks and, therefore, proprietary of their respective owners.



Explanation of Symbols



CE Conformity

This symbol indicates that the item described in this manual is in compliance with all applied CE standards. See also the section “Applied standards” of this manual.



Caution!

This symbol and title warn you of hazards due to electrical shocks (> 60 V) when touching products or parts of them. The non-observance of the measures indicated and/or prescribed by the law may cause harm to your product and/or life/health.

See also the section “High Voltage Safety Instructions”.



ESD-Sensitive Device!

This symbol and title inform you that electronic boards and their components are sensitive to static electricity. Therefore, care must be taken during all handling operations and inspections of this product, in order to ensure product integrity at all times.

Please read also the section “Special Handling and Unpacking Instructions” of this manual.



Attention!

This symbol and title emphasize aspects which, if not read through carefully by the reader, might cause hazards to health and/or damages to material.



Note:

This symbol and title emphasize aspects the reader should read through carefully for his or her own advantage.



PEP Advantage

This symbol and title emphasize advantages or positive aspects of a product and/or procedure.



Troubleshooting

This symbol and title characterize a message containing useful information on troubleshooting and problem solving.



For your safety

Your new *PEP* product was developed and tested carefully to provide all features necessary to ensure the renown electrical safety requirements. It was also designed for a long fault-free life. However, the life expectancy of your product can be drastically reduced by improper treatment during unpacking and installation. Therefore, in the interests of your own safety and of the correct operation of your new *PEP* product, you are requested to conform with the following guidelines.

High Voltage Safety Instructions



Warning!

All operations on this device must be carried out by sufficiently skilled personnel only.



Caution!

However, serious electrical shock hazards exist during all installation, repair and maintenance operations with this product. Therefore, always unplug the power cable to avoid exposure to hazardous voltage.




Before installing your new *PEP* product into a system always ensure that your mains power is switched off. This applies also to the installation of piggybacks.

Special Handling and Unpacking Instructions



ESD Sensitive Device!

Electronic boards and their components are sensitive to static electricity. Therefore, care must be taken during all handling operations and inspections of this product, in order to ensure product integrity at all times.

-  Do not handle this product out of its protective enclosure while it is not used for operational purposes, unless it is otherwise protected.
-  Whenever possible, unpack or pack this product only at EOS/ESD safe work stations. Where safe work stations are not guaranteed, it is important for the user to be electrically discharged before touching the product with his/her hands or tools. This is most easily done by touching a metal part of your system housing.
-  It is particularly important to observe standard anti-static precautions when changing piggybacks, ROM devices, jumper settings etc. If the product contains batteries for RTC or memory back-up, ensure that the board is not placed on conductive surfaces, including anti-static plastics or sponges. They can cause short circuits and damage the batteries or tracks on the board.



General Instructions on Usage

- ☞ In order to maintain *PEP's* product warranty, this product must not be altered or modified in any way. Changes or modifications to the device, which are not explicitly approved by *PEP Modular Computers* and described in this manual or received from *PEP* Technical Support as a special handling instruction, will void your warranty.
- ☞ This device should only be installed in or connected to systems that fulfill all necessary technical and specific environmental requirements. This applies also to the operational temperature range of the specific board version, which must not be exceeded. If batteries are present, their temperature restrictions must be taken into account.
- ☞ In performing all necessary installation and application operations, please, follow only the instructions supplied by the present manual.
- ☞ Keep all the original packaging material for future storage or warranty shipments. If it is necessary to store or ship the board please re-pack it as nearly as possible in the manner in which it was delivered.
- ☞ Special care is necessary when handling or unpacking the product. Please, consult the special handling and unpacking instruction on the previous page of this manual.



Two Years Warranty

PEP Modular Computers grants the original purchaser of *PEP* products a **TWO YEARS LIMITED HARDWARE WARRANTY** as described in the following. However, no other warranties that may be granted or implied by anyone on behalf of *PEP* are valid unless the consumer has the express written consent of *PEP Modular Computers*.

PEP Modular Computers warrants their own products, excluding software, to be free from manufacturing and material defects for a period of 24 consecutive months from the date of purchase. This warranty is not transferable nor extendible to cover any other users or long-term storage of the product. It does not cover products which have been modified, altered or repaired by any other party than *PEP Modular Computers* or their authorized agents. Furthermore, any product which has been, or is suspected of being damaged as a result of negligence, improper use, incorrect handling, servicing or maintenance, or which has been damaged as a result of excessive current/voltage or temperature, or which has had its serial number(s), any other markings or parts thereof altered, defaced or removed will also be excluded from this warranty.

If the customer's eligibility for warranty has not been voided, in the event of any claim, he may return the product at the earliest possible convenience to the original place of purchase, together with a copy of the original document of purchase, a full description of the application the product is used on and a description of the defect. Pack the product in such a way as to ensure safe transportation (see our safety instructions).

PEP provides for repair or replacement of any part, assembly or sub-assembly at their own discretion, or to refund the original cost of purchase, if appropriate. In the event of repair, refunding or replacement of any part, the ownership of the removed or replaced parts reverts to *PEP Modular Computers*, and the remaining part of the original guarantee, or any new guarantee to cover the repaired or replaced items, will be transferred to cover the new or repaired items. Any extensions to the original guarantee are considered gestures of goodwill, and will be defined in the "Repair Report" issued by *PEP* with the repaired or replaced item.

PEP Modular Computers will not accept liability for any further claims resulting directly or indirectly from any warranty claim, other than the above specified repair, replacement or refunding. In particular, all claims for damage to any system or process in which the product was employed, or any loss incurred as a result of the product not functioning at any given time, are excluded. The extent of *PEP Modular Computers* liability to the customer shall not exceed the original purchase price of the item for which the claim exists.

PEP Modular Computers issues no warranty or representation, either explicit or implicit, with respect to its products' reliability, fitness, quality, marketability or ability to fulfil any particular application or purpose. As a result, the products are sold "as is," and the responsibility to ensure their suitability for any given task remains that of the purchaser. In no event will *PEP* be liable for direct, indirect or consequential damages resulting from the use of our hardware or software products, or documentation, even if *PEP* were advised of the possibility of such claims prior to the purchase of the product or during any period since the date of its purchase.

Please remember that no *PEP Modular Computers* employee, dealer or agent is authorized to make any modification or addition to the above specified terms, either verbally or in any other form, written or electronically transmitted, without the company's consent.



Table of Contents

Chapter 1

1. Introduction.....	1 - 3
1.1 Product Overview	1 - 3
1.2 Board Overview.....	1 - 3
1.3 Functional Block Diagram.....	1 - 4
1.4 PB-SIO4 External Interfacing	1 - 5
1.5 Carrier Board External Connectors	1 - 5
1.6 Technical Specifications	1 - 6
1.7 Applied Standards	1 - 7
1.8 Related Publications.....	1 - 7

Chapter 2

2. Installation	2 - 3
2.1 Board Installation.....	2 - 3
2.2 Software Installation	2 - 4

Chapter 3

3. Configuration.....	3 - 3
3.1 PB-SIO4 Address Map and ID Byte	3 - 3
3.2 VMEbus Interrupts.....	3 - 3
3.3 Jumper Settings.....	3 - 4
3.4 Pinouts.....	3 - 5



Chapter **4**

4. Adapter AD-SIO4.....	4 - 3
4.1 Product Overview	4 - 3
4.2 Adapter Overview	4 - 3



Chapter 1

Introduction

1.1	Product Overview.....	1 - 3
1.1.1	Description	1 - 3
1.1.2	Features	1 - 3
1.2	Board Overview	1 - 3
1.3	Functional Block Diagram	1 - 4
1.4	PB-SIO4 External Interfaceing.....	1 - 5
1.5	Carrier Board External Connectors.....	1 - 5
1.6	Technical Specifications	1 - 6
1.7	Applied Standards.....	1 - 7
1.7.1	CE Compliance.....	1 - 7
1.7.2	Mechanical Compliance.....	1 - 7
1.7.3	Environmental Tests.....	1 - 7
1.8	Related Publications	1 - 7
1.8.1	General	1 - 7
1.8.2	PEP Modular Computers	1 - 7

This page was intentionally left blank.



1. Introduction

1.1 Product Overview

1.1.1 Description

The PB-SIO4 is a quad (four) channel asynchronous RS232 serial piggyback with support for full duplex RS232 transmit, receive, and RTS/CTS handshake signals.

There are two different versions of the PB-SIO4 available: non-optoisolated and optoisolated. Any version combination can be installed on a single carrier board. Interfacing to the PB-SIO4 depends on the type of connector provided by the carrier board or optional adapters.

1.1.2 Features

General:

- Interrupt request line employed, interrupt vector generated by the DUART's.
- Board ID byte for remote (software) configuration identity checking.
- Compact size, four serial ports within standard industrial I/O piggyback dimensions.
- Easy to maintain. Quick and simple replacement if required.

Hardware:

- Full electrical and mechanical compatibility with the extensive range of carrier boards.
- All required VMEbus lines are available on the piggyback.
- Optional optoisolated driver/receiver supporting TxD, RxD, CTS, and RTS.
- Optional interface adapters with four 15-pin D-sub connectors. (See Adapter AD-SIO4 chapter this manual.)
- Extended temperature version available for harsh industrial environments.

1.2 Board Overview

The PB-SIO4 has two connectors for interfacing to the carrier board. Connector ST1 interfaces to the CPU side of the carrier board whereas connector ST2 provides interfacing to the external interface side of the carrier board.

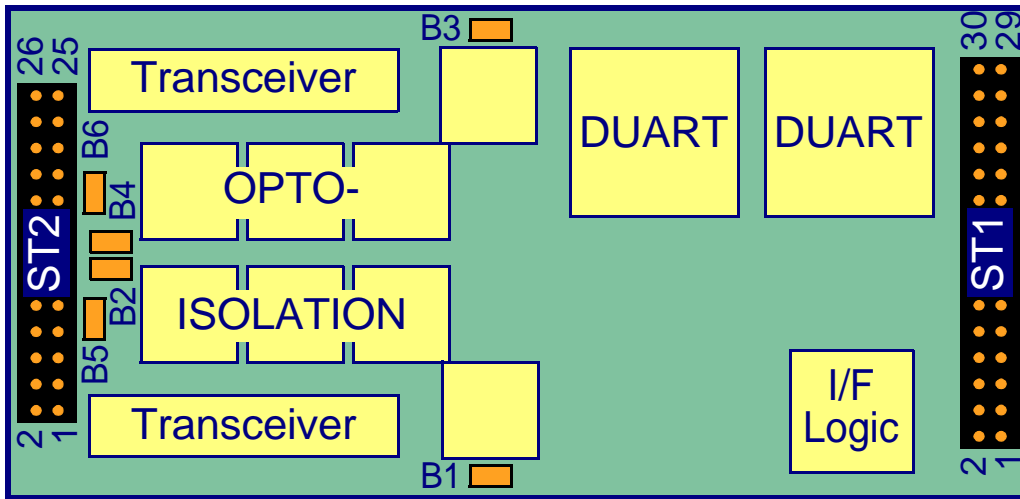
This piggyback is fitted with DUART devices (two driver/receiver devices each handling two of the four serial channels), as well as a GAL device containing the specific interrupt handling logic and other features such as the I.D. number.

The optoisolated versions have eight optocouplers which are replaced with wire bridges on the non-optoisolated versions.

Operational configuration of this piggyback is done via jumpers, B1 - B6, located on the front side of the board.

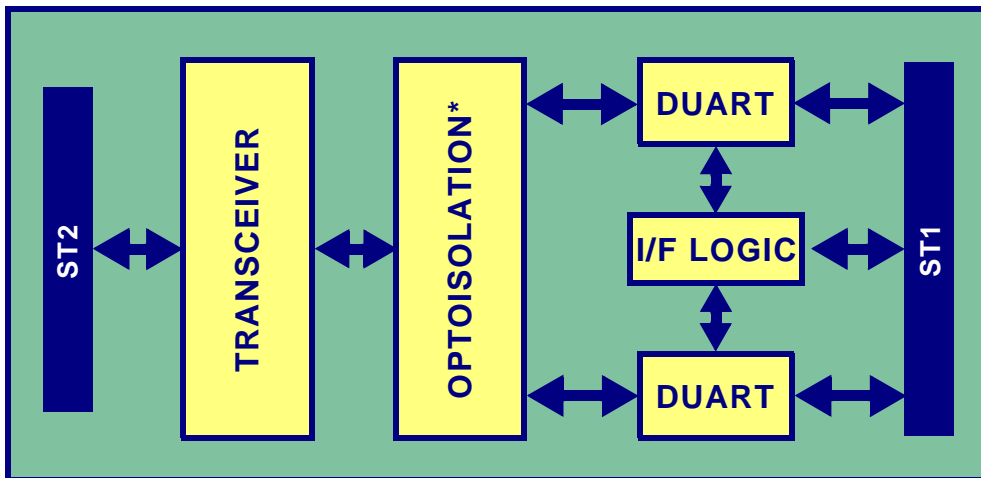


Figure 1-1: PB-SIO4 Board Front View (Optoisolated Version)



1.3 Functional Block Diagram

Figure 1-2: Functional Block Diagram of the PB-SIO4



* Optoisolation is optional



1.4 PB-SIO4 External Interfacing

Connection of the PB-SIO4 piggyback to external devices is a function of the specific carrier board for the piggyback. In conjunction with the carrier board there are various possibilities for connecting the I/O channels of the piggyback to external devices.

For the carrier boards themselves there are three types of connectors available.

Front Panel:

- 50-pin male, double row, flat-ribbon cable connector head, locking
- 50-pin female, Dsub connector

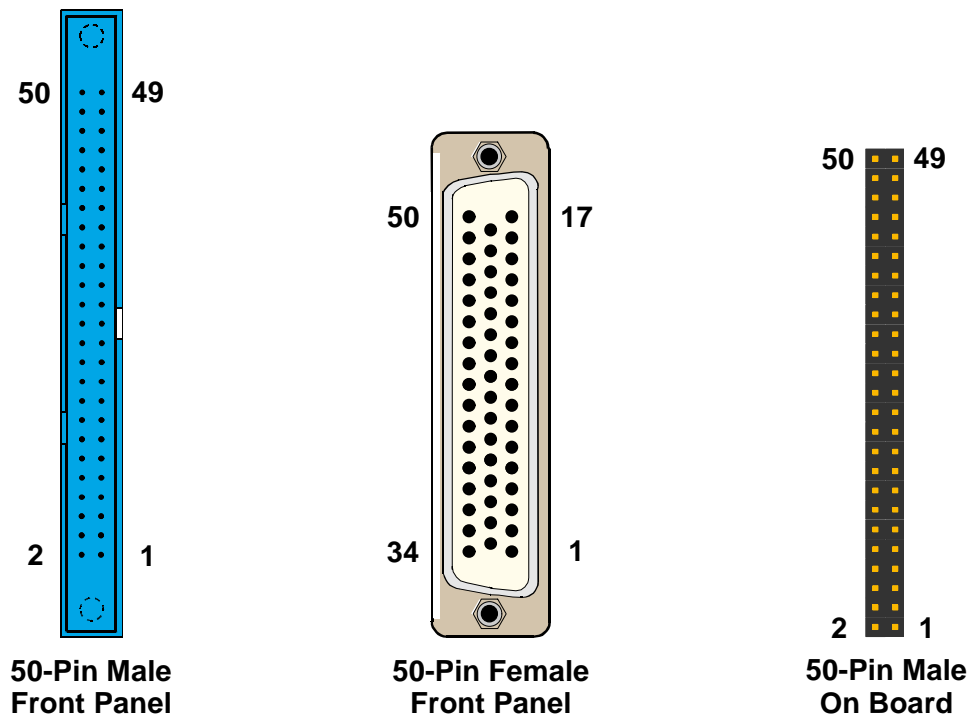
On-Board:

- 50-pin male, double row, flat-ribbon cable connector head

In conjunction with the carrier board's connectors, there is also the possibility of providing connection to external devices using the AD-SIO4 adapter. This adapter utilizes either of the carrier board's flat-ribbon connectors to provide 4, 15-pin female, Dsub connectors. One connector for each channel of the PB-SIO4. Two PB-SIO4's and two of these adapters can be combined to provide 8 serial I/O channels. The AD-SIO4 is optional and must be ordered separately. See chapter 4 of this manual for a description of the AD-SIO4.

1.5 Carrier Board External Connectors

Figure 1-3: Carrier Board External Connector Types





1.6 Technical Specifications

Table 1-1: PB-SIO4 Technical Specification

PB-SIO4	Specification
Standard	RS232
Number of Channels	four per PB-SIO4 module
Controller	two MC68681 DUART's (one pro port pair)
Transfer Rates	asynchronous: up to 38 kBaud or 115 kBaud depending on board population
Programmable Data Format	<ul style="list-style-type: none"> • 5 ... 8 bit, plus parity • odd, even, no parity, and force parity • 1, 1½, and 2 stop bits
Programmable Channel Modes	<ul style="list-style-type: none"> • normal, full duplex • automatic echo • local loopback • remote loopback
Counter / Timer	two 16-bit (one for each DUART)
Identification Byte	F7 hex
DTACK Generation	on board
Power Supply	5V DC, ± 5%
Power Consumption	0.4A, typical
Temperature Range	Operating: 0°C ... +70°C (Standard) -40°C ... +85°C (Extended)
Humidity	0 ... 95% non-condensing
Dimensions	Width: 48 mm (1 ⁷ / ₈ inches) Length: 100 mm (3 ¹⁵ / ₁₆ inches) Depth: 12 mm (1 ¹ / ₂ inches)
Weight	110 grams
Carrier Board Interface	two, dual row male header connectors providing all necessary communication paths and mechanical mounting



1.7 Applied Standards

1.7.1 CE Compliance

The *PEP Modular Computers'* VME products comply with the requirements of the following CE-relevant standards:

- Emission EN50081-1
- Immission EN50082-2
- Electrical Safety EN60950

1.7.2 Mechanical Compliance

- Mechanical Dimensions IEEE 1101.10

1.7.3 Environmental Tests

- Vibration/Broad-Band IEC68-2-6
- Random Vibration IEC68-2-64 (3U boards)
- Permanent Shock IEC68-2-29
- Single Shock IEC68-2-27

1.8 Related Publications

1.8.1 General

- VMEbus Specification, Revision C.1
- The MC68681 data sheet from Motorola

1.8.2 PEP Modular Computers

Please contact PEP Modular Computers concerning the following product manuals.

- VMOD2
- VMOD2D
- VMOD4D
- IMOD
- V642
- V662

This page was intentionally left blank.



Chapter **2**

Installation

2.1 Board Installation	2 - 3
2.2 Software Installation.....	2 - 4
2.2.1 Driver Installation	2 - 4

This page was intentionally left blank.



2. Installation

2.1 Board Installation



Caution!

Switch off all power to the system and ensure that there are **NO** external cables connected to the carrier board or to any optional adapters connected to the carrier board before installing the PB-SIO4. Failure to do so could endanger your life/health and may damage your board or system.



ESD Equipment!

Your PB-SIO4 board contains electrostatically sensitive devices. Please observe the necessary precautions to avoid damage to your board:

- Discharge your clothing before touching the assembly. Tools must be discharged before use.
- Do not touch components, connector-pins or traces.
- If working at an anti-static workbench with professional discharging equipment, please do not omit to use it.



Note!

The PB-SIO4 can be installed in any free carrier board position, and can be combined with any other type of piggyback module on a carrier board. The only restraint here being the external interfacing requirements, in particular, what type of cable connection is required. It is the responsibility of the system integrator to ensure proper external interfacing to the PB-SIO4.

To install a PB-SIO4 piggyback proceed as follows:

- ensure that the safety requirements indicated above are observed
- as required, ensure that the piggyback and carrier board are properly configured (see appropriate documentation for configuration)
- if required, remove the carrier board and optional adapters from the system
- ensure the proper orientation of the PB-SIO4 to the carrier board before installing (see appropriate documentation for orientation)
- press the piggyback onto the carrier board until fully seated



Note!

The PB-SIO4 can be securely mounted to the carrier board via screws and stand offs as appropriate.



- if required, repeat this process for a second piggyback on this carrier board
- install the carrier board and optional adapters as required
- connect external interfacing cables to the carrier board and optional adapters as required
- ensure that the carrier board, optional adapters, and interfacing cables are properly secured

2.2 Software Installation

2.2.1 Driver Installation

Drivers are available for various operating systems but are not delivered with the PB-SIO4. If required, please order the appropriate driver separately.

For installation of any required driver, please refer to the driver documentation itself.



Chapter **3**

Configuration

3.1	<i>PB-SIO4 Address Map and ID Byte</i>	3 - 3
3.2	<i>VMEbus Interrupts.....</i>	3 - 3
3.3	<i>Jumper Settings.....</i>	3 - 4
3.4	<i>Pinouts.....</i>	3 - 5
3.4.1	<i>PB-SIO4/Carrier Board Connector ST1</i>	3 - 5
3.4.2	<i>PB-SIO4/Carrier Board Connector ST2</i>	3 - 6
3.4.3	<i>PB-SIO4 to Carrier Board to AD-SIO4.....</i>	3 - 7

This page was intentionally left blank.



3. Configuration

3.1 PB-SIO4 Address Map and ID Byte

The PB-SIO4 is addressed (odd byte access) by using the carrier board base address and one of the following offsets for the piggyback location:

Piggyback location A (the upper position on the carrier board)

Base Address + \$01	DUART1
Base Address + \$21	DUART2
Base Address + \$41	ID Byte

Piggyback location B (the lower position on the carrier board)

Base Address + \$81	DUART1
Base Address + \$A1	DUART2
Base Address + \$C1	ID Byte

The PB-SIO4 has an ID Byte of \$F7 (RS232).

3.2 VMEbus Interrupts

Each DUART device is able to issue an interrupt request (*IRQ) to the carrier board. In the event of simultaneous interrupt requests those from DUART #1 have priority over those from DUART #2.

The interrupt level is set by the carrier board. See the carrier board documentation for setting of the level. The interrupt vector itself is provided by the DUART.



3.3 Jumper Settings

The jumper positions B1 to B6 are located on the front side of the PB-SIO4. They are set at the factory as required and should not be changed.



Note!

Jumpers B1 through B6 are zero-Ohm resistors.

Before operating the PB-SIO4 ensure that the jumper settings are set correctly according to the application. No external VCC may be applied to the non-optocoupler version, and, correspondingly, external VCC must be applied to optocoupler versions.

Table 3-1: Jumpers B1 to B6: Settings According to Version

JUMPERS						VERSION
B1	B2	B3	B4	B5	B6	
closed	closed	closed	closed	open	open	Non-Optocoupler
open	open	open	open	closed	closed	Optocoupler



3.4 Pinouts

3.4.1 PB-SIO4/Carrier Board Connector ST1

This is a thirty pin, dual row male header connector which provides interfacing between the PB-SIO4 and CPU side of the carrier board.

Table 3-2: Pinout of Connector ST1

Signal	Pin	Pin	Signal
+5V (Vcc)	30	29	GND
IA1	28	27	ID0
IA2	26	25	ID1
IA3	24	23	ID2
IA4	22	21	ID3
IA5	20	19	ID4
IA6	18	17	ID5
\overline{IAS}	16	15	ID6
$\overline{IDS0}$	14	13	ID7
N/C	12	11	\overline{INT}
\overline{CS}	10	9	\overline{INTA}
\overline{DTACK}	8	7	\overline{RESET}
CLK	6	5	$\overline{R/W}$
-12V	4	3	+12V
+5V (Vcc)	2	1	GND



3.4.2 PB-SIO4/Carrier Board Connector ST2

This is a twenty-six pin, dual row male header connector which provides interfacing between the PB-SIO4 and the application side of the carrier board.

Table 3-3: Pinout of Connector ST2

Signal	Pin	Pin	Signal
RxD D	26	25	RxD D
GndE1	24	23	CTSA
TxD A	22	21	+5V VccE1
RxD A	20	19	RTSA
GndE1	18	17	CTSB
TxD B	16	15	+5V VccE1
RxD B	14	13	RTSB
GndE2	12	11	CTSC
TxD C	10	9	+5V VccE2
RxD C	8	7	RTSC
GndE2	6	5	CTSD
TxD D	4	3	+5V VccE2
RTSD	2	1	RTSD



3.4.3 PB-SIO4 to Carrier Board to AD-SIO4

Table 3-4: PB-SIO4 to Carrier Board to AD-SIO4 Pinout Table (Both Positions)

POS./DUART		Signal	ST2	Carrier Board		AD-SIO4 BU5	AD-SIO4 Front Panel		
P	D						PINS	CON/CH	
U P P E R	2	RTSD	1, 2	50		24	5	BU4	D
		RxD D	25,26		49	23	3		
		VccE2	3	48		22	15		
		TxD D	4		47	21	2		
		CTSD	5	46		20	3		
		GndE2	6		45	19	1,7		
	2	RTSC	7	44		18	5	BU3	C
		RxD C	8		43	17	3		
		VccE2	9	42		16	15		
		TxD C	10		41	15	2		
		CTSC	11	40		14	4		
		GndE2	12		39	13	1,7		
	1	RTSB	13	38		12	5	BU2	B
		RxD B	14		37	11	3		
		VccE1	15	36		10	15		
		TxD B	16		35	9	2		
		CTSB	17	34		8	4		
		GndE1	18		33	7	1,7		
1	RTSA	19	32		6	5	BU1	A	
	RxD A	20		31	5	3			
	VccE1	21	30		4	15			
	TxD A	22		29	3	2			
	CTSA	23	28		2	4			
	GndE1	24		27	1	1,7			
				26	not used				
				25	not used				



Table 3-4: PB-SIO4 to Carrier Board to AD-SIO4 Pinout Table (Both Positions)

POS./DUART		Signal	ST2	Carrier Board		AD-SIO4 BU5	AD-SIO4 Front Panel	
P	D						PINS	CON/CH
L O W E R	2	RTSD	1, 2	24		24	5	BU4 D
		RxD D	25,26		23	23	3	
		VccE2	3	22		22	15	
		TxD D	4		21	21	2	
		CTSD	5	20		20	3	
		GndE2	6		19	19	1,7	
	2	RTSC	7	18		18	5	BU3 C
		RxD C	8		17	17	3	
		VccE2	9	16		16	15	
		TxD C	10		15	15	2	
		CTSC	11	14		14	4	
		GndE2	12		13	13	1,7	
	1	BU2 B	RTSB	13	12		12	5
			RxD B	14		11	11	3
			VccE1	15	10		10	15
			TxD B	16		9	9	2
			CTSB	17	8		8	4
			GndE1	18		7	7	1,7
BU1 A		RTSA	19	6		6	5	
		RxD A	20		5	5	3	
		VccE1	21	4		4	15	
		TxD A	22		3	3	2	
CTSA	23	2		2	4			
GndE1	24		1	1	1,7			

Legend: POS(ition)/DUART, P, D; CON/CH

where: P = position on carrier board
 D = DUART
 CON = connector
 CH = channel



Chapter **4**

Adapter AD-SIO4

<i>4.1 Product Overview</i>	<i>4 - 3</i>
<i>4.2 Adapter Overview</i>	<i>4 - 3</i>

This page was intentionally left blank.



4. Adapter AD-SIO4

4.1 Product Overview

The AD-SIO4 is a special adapter designed to provide front panel connection to the PB-SIO4 using 15-pin Dsub connectors as opposed to the 50-pin connector provided by the carrier board.

This adapter consists of a separate, 8 HP front panel with four, 15-pin female Dsub connectors mounted on the front side for external device connection, and two, 24-pin, male dual row connectors for internal connection to the PB-SIO4 carrier board. Connection from the carrier board to the adapter is done via a 50-way, flat ribbon cable with a 50-pin, dual row female connector for the carrier board, and two, 24-pin, dual row female connectors for connection to the adapter. This cable allows for the connection of two PB-SIO4's to two AD-SIO4's where pins 25 and 26 are not used. See Table 3-4 for the pinout of this cable.

4.2 Adapter Overview

Figure 4-1: Front View of the AD-SIO4 with Dsub Pin Layout

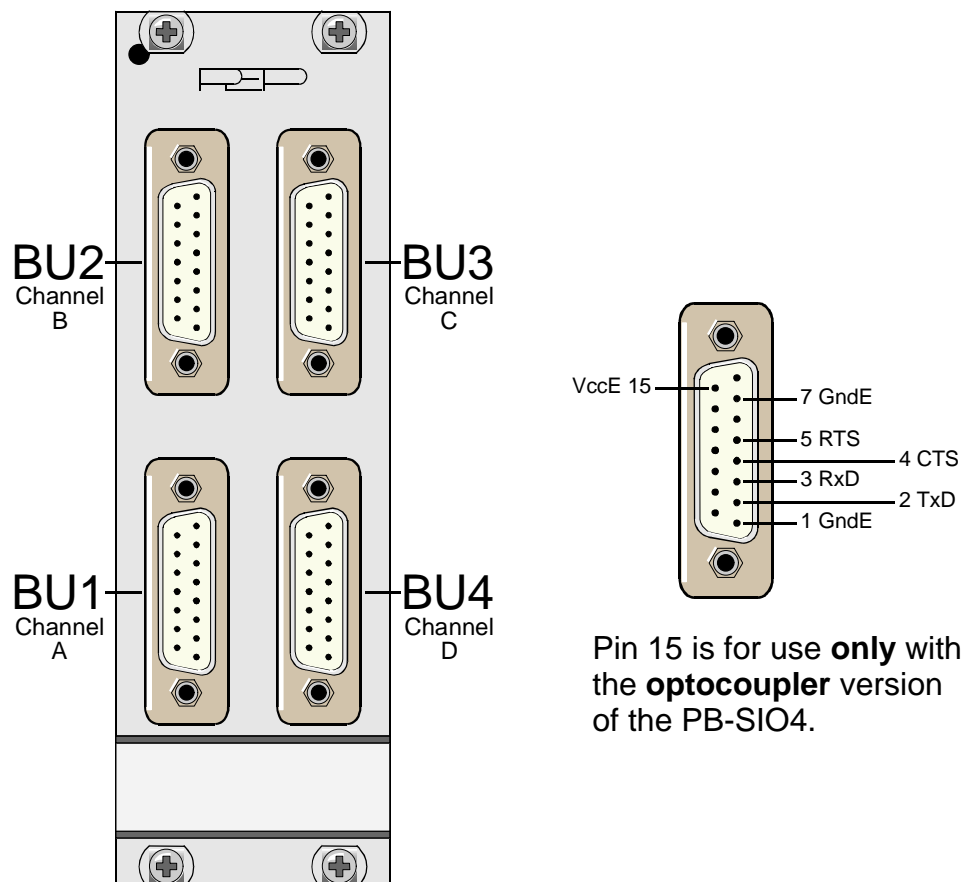
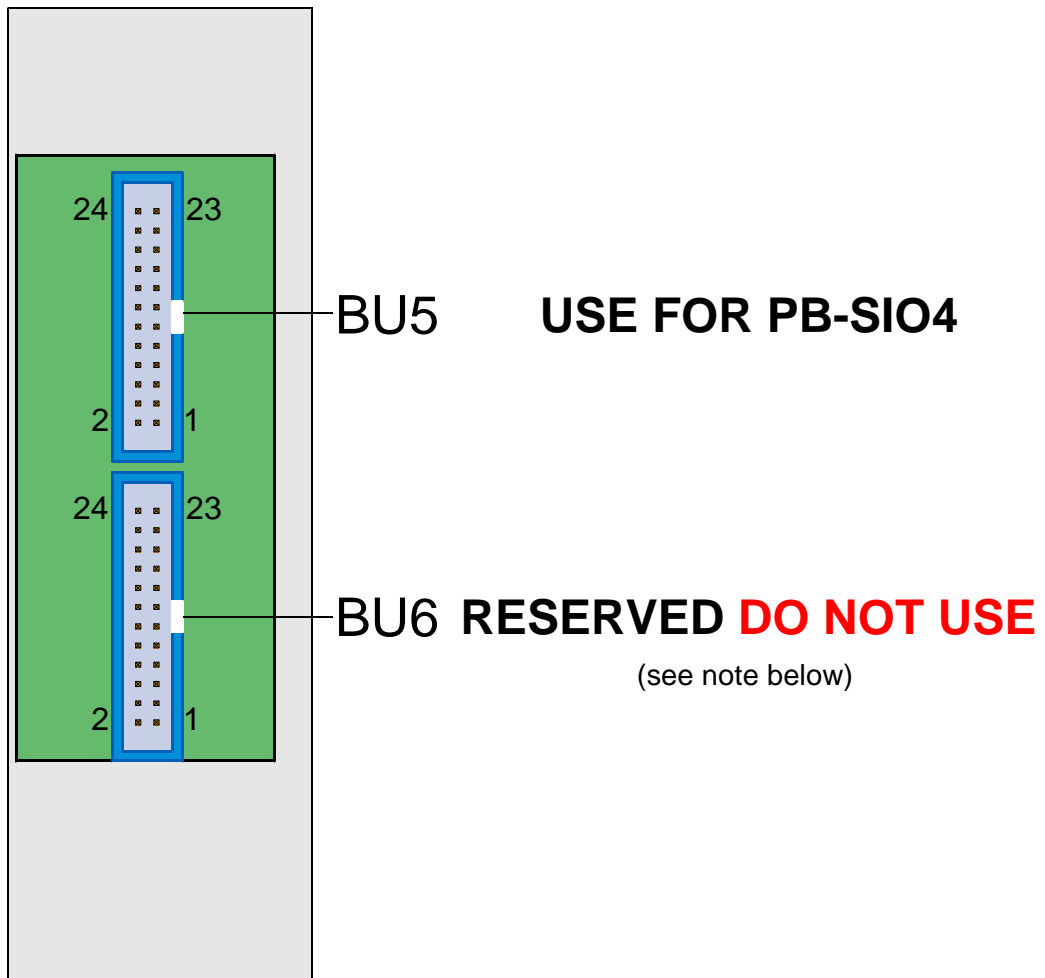




Figure 4-2: Rear View of the AD-SIO4



Connector BU5 is for use with the PB-SIO4. Connector BU6 is reserved for use with the PB-SIO4A, another serial interface piggyback from PEP.



Note!

Always ensure that the correct connector of the adapter cable is connected to BU5. See Table 3-4 for cable pinout.



Note!

For use with the PB-SIO4 ensure that there is no cable connected to BU6. Failure to comply with this will result in malfunctioning and possible damage to equipment.