

# **IP-4PGP23**

## **Series**

(Full-Size Single Board Computer)

# **INSTALLATION GUIDE**

Installation Guide Revision C0  
60070024PG0C0



**COPYRIGHT®**

All rights reserved. The information contained in this guide has been validated and reviewed for accuracy. No patent liability is assumed with respect to the use of the information contained herein. While every precaution has been taken in the preparation of this guide, the Manufacturer assumes no responsibility for errors or omissions.

No part of this publication may be reproduced, stored in a retrieval system, or transmitted in any form or by any means, electronic, mechanical, photocopying, recording, or otherwise, without the prior written permission of Manufacturer.

**TRADEMARK™**

Intel®, Pentium® and Celeron® are registered trademarks of Intel® Corporation.

Microsoft® and Windows® are registered trademarks of Microsoft Corporation.

All products and company names are trademarks or registered trademarks of their respective holders.

These specifications are subject to change without notice.

Installation Guide Revision C0  
August 2006

# CONTENTS

<b>SECTION 1 INTRODUCTION</b>	<b>1</b>
1.1 Unpacking IP-4PGP23 Series	1
1.2 Description	3
1.3 Features	3
1.3.1 Hardware Monitoring	4
1.3.2 I/O Shield Connector	4
1.3.3 IP-4PGP23 Series Overview	4
1.3.4 System Block Diagram	5
1.4 Specifications	6
<b>SECTION 2 INSTALLATIONS</b>	<b>8</b>
2.1 System Installation	8
2.1.1 CPU Installation	8
2.1.2 Heat Sink Installation	9
2.1.3 Memory Module Installation	10
2.1.4 Setting Jumpers	11
2.2 Board Layout	12
2.3 Jumper Setting	13
2.4 Connector's Description	14
2.5 Optional IP-ALCS20 Audio Card	28

## CONTENTS

<b>SECTION 3</b>	<b>AWARD BIOS SETUP</b>	<b>30</b>
3.1	BIOS Instructions	30
3.2	Main Menu	31
3.3	Standard CMOS Features	33
3.4	IDE Adapters	35
3.5	Advanced BIOS Features	37
3.6	Advanced Chipset Features	42
3.7	Integrated Peripherals	45
3.8	Power Management Setup	50
3.9	PnP/PCI Configurations	54
3.10	PC Health Status	56
3.11	Frequency/Voltage Control	58
3.12	Load Fail-Safe Default	59
3.13	Load Optimized Defaults	59
3.14	Supervisor/User Password Setting	60
3.15	Exit Selecting	61



# SECTION 1

## INTRODUCTION

### 1.1 Unpacking IP-4PGP23 Series

1. Take out the IP-4PGP23 series unit from the carton box, check if the unit is properly secure in the plastic bag.

2. Check the contents of the carton box:

◆ Single Board Computer

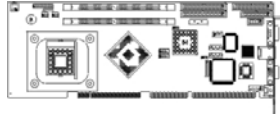

◆ Installation Guide

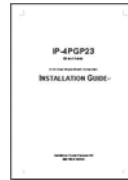

◆ Floppy ribbon cable



◆ ATA-66/100 HDD ribbon cable



◆ CD Driver



◆ Printer & COM1 ribbon cable

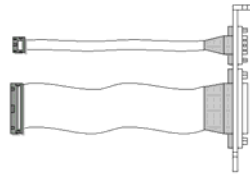

Introduction

- ◆ K/B & M/S Y type cable



- ◆ K/B extend to BP cable (5-pins to 6-pins)



- ◆ ATX power control cable (4-pins to 4-pins)



- ◆ USB 2.0 cable (1 Set)

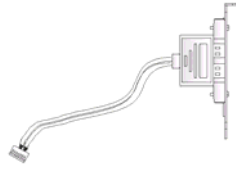

- ◆ S-ATA cable



3. Optional Audio Card / Cable

- ◆ IP-ALCS20 Audio Card

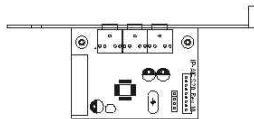

- ◆ Audio 9-pins round cable



## 1.2 Description

The IP-4PGP23 Series single board computer is optimized for socket 478 FC-PGA processor, supporting 800/533MHz Front Side Bus, the memory can accommodate is up to 2GB DDR333/400 SDRAM. This board is based on the Intel® 865G chipset and is fully designed for harsh industrial environment. The IP-4PGP23 series is 800MHz FSB with chipset (GMCH) on-die enhanced Intel® Extreme Graphics 2 and one 10/100/1000 Mbps Gigabit Ethernet controller. It is for CTI and high-performance applications.

The other I/O function include two SATA ports, two serial ports, one parallel port, two ATA100 IDE interface, one FDC interface, four USB 2.0 ports, Watchdog Timer and PS/2 Keyboard or Mouse.

## 1.3 Features

- ◆ Intel® Pentium® 4 / Celeron® processor
- ◆ Intel® 865G + ICH5 AGPset
- ◆ Support 2GB DDR333/400 SDRAM (Max.) Memory
- ◆ Front Side Bus Frequency: 533 / 800 MHz
- ◆ Chipset integrated AGP8X graphic function
- ◆ Single 10/100/1000 Mbps Gigabit Ethernet using Intel® 82547GI chip
- ◆ Software programmable watchdog timer
- ◆ Hardware Monitoring
- ◆ AC97 Audio pin-header (Option IP-ALCS20 audio card)

### 1.3.1 Hardware Monitoring

Hardware monitoring allows you to monitor various aspects of your systems operations and status. The features include CPU temperature, voltage and RPM of fan.

### 1.3.2 I/O Shield Connector

The SBC is equipped with an I/O bracket. Please use the appropriate I/O shield (figure 1).

IP-4PGP23 Series

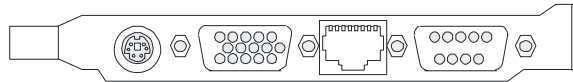

Figure 1: I/O bracket layout

### 1.3.3 IP-4PGP23 Series Overview

Function / Model	IP-4PGP23
◆ Chipset	i865G
◆ VGA function	◎ (i865G)
◆ Gigabit Ethernet function	◎
◆ AC97 Audio	Pin-header (Option IP-ALCS20 Audio Card)
◆ Two EIDE interface	◎
◆ Two SATA interface	◎
◆ One Floppy interface	◎
◆ Two Serial, One Parallel	◎
◆ Four USB 2.0 ports	◎

### 1.3.4 System Block Diagram

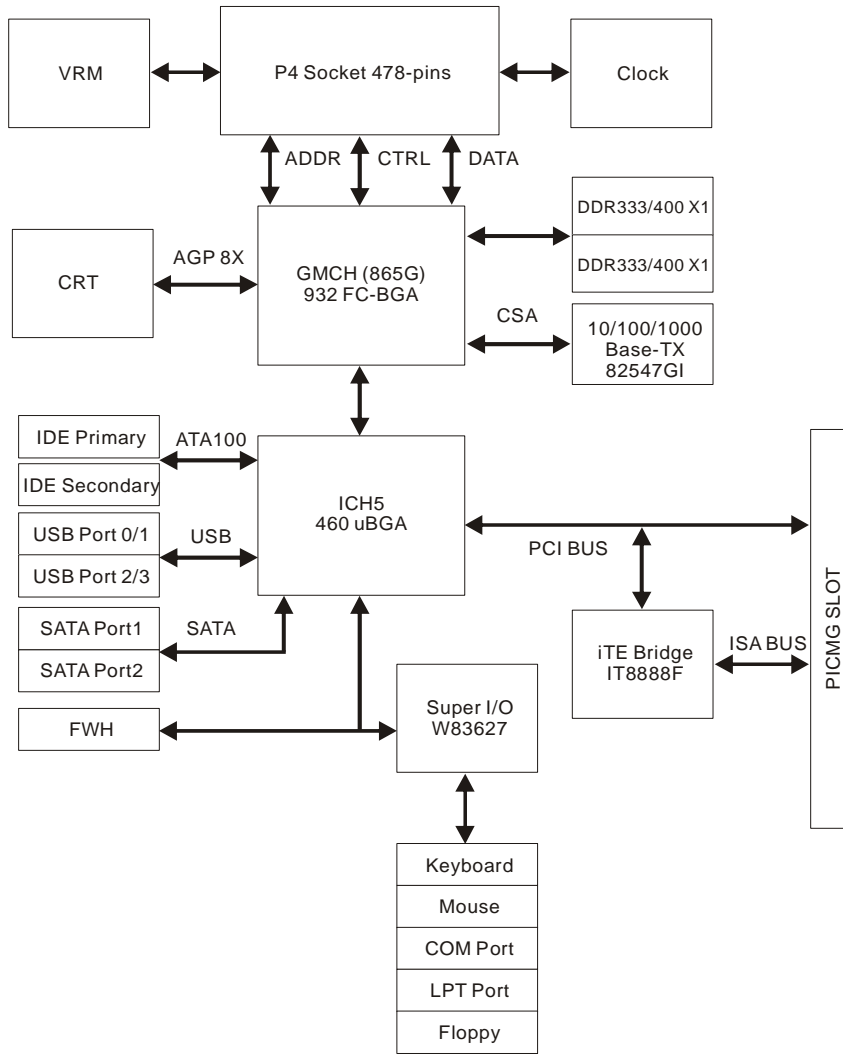

Figure 2: System Block Diagram

## 1.4 Specifications

IP-4PGP23:

- ◆ **Processor:**
  - Socket 478 processors, for Intel® Pentium® 4/ Celeron® processor
- ◆ **Chipset:**
  - Intel® 865G + ICH5 AGPset
- ◆ **Front Side Bus:**
  - 400 / 533 / 800 MHz
- ◆ **DRAM Module:**
  - 2 x 184pins DIMM for DDR SDRAM up to 2GB (max.)
  - Support DDR 266 / 333 / 400 SDRAM
- ◆ **VGA Function:**
  - Intel® 865G chipset integrated graphic function
- ◆ **Gigabit Ethernet Function:**
  - Intel® 82547GI Gigabit Ethernet controller
  - For 10 / 100 / 1000 Base-TX Ethernet
- ◆ **Audio Function: (Optional)**
  - AC97 audio interface, by option audio card --- IP-ALCS20
  - Onboard 9-pins (pin-header) interface
- ◆ **SATA Function:**
  - Two S-ATA ports, support data transfer rates up to 150MB/s
- ◆ **Onboard I/O:**
  - On-Chip I/O integrated with K/B, Mouse, FDD, Parallel and Serial controller
- ◆ **Onboard PCI / IDE:**
  - Intel® ICH5 South Bridge controller
  - PCI Rev2.2 Compliant
  - ACPI Compliant Power Management
  - PCI Bus IDE Port with PIO /ATA-100 x 2 (Up to 4 Devices)

- ◆ **Bracket I/O Connectors:**
  - D-Sub Serial port (COM1)
  - Single RJ-45 connector
  - 15-pins D-Sub VGA connector
  - PS/2 style Mouse or Keyboard connector
  
- ◆ **USB 2.0 Ports:**
  - 4 x USB 2.0 ports (pin-header)
  
- ◆ **BIOS:**
  - Award Plug & Play BIOS
  
- ◆ **Extended Function:**
  - Hardware monitoring function
  - IrDA by pin-header
  
- ◆ **Form Factor:**
  - 13.3" x 4.8" (338 x 122mm)
  
- ◆ **Weight:**
  - 0.93lb (420g) --- IP-4PGP23

## SECTION 2

### INSTALLATIONS

#### 2.1 System Installation

##### 2.1.1 CPU Installation

Carefully follow the steps below in order to install the CPU:

1. Check and confirm that you are going to install correctly CPU type and pin numbers (figure 3).
2. Lift the releasing lever of the Socket 478.
3. Align the pins of the CPU against the pinholes of the Socket 478. Be sure to pay attention to the orientation of the CPU.

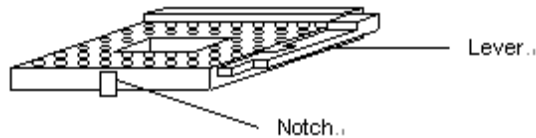

Figure 3: CPU Socket

4. Push down the CPU into the Socket 478.
5. Push down the release lever and lock it against the key hook.
6. Hook the hole in ZIF clip for the CPU cooling fan onto the notch on the socket 478.
7. Place the CPU cooling fan atop the CPU surface.
8. Push down the opposite side of the ZIF clip and hook it.
9. Slide the head of the clip to left and lock it.
10. Connect the cooling fan cable to the socket. Be careful not to place the cable on the CPU cooling fan.

**Removing a CPU:**

1. Before removing the CPU, turn off the system board power; then wait for about 3 minutes until the heat radiation plate of the cooling fan and the CPU cool down.
2. To remove the CPU, lift the releasing lever of the Socket 478.

Note: The CPU and the heat radiation plate are hot. They may cause burns.

**To remove the CPU, reverse the installation steps.**

**2.1.2 Heat Sink & Retention Module Installation**

It is highly recommended that only IP-4PGP23 Heat Sink + Fan (figure 4), designed for use in the chassis be used -- the use of other heat sinks, including those boxed with CPUs, may result in damage to the IP-4PGP23 SBC.

Make sure that good contact is made between the processors and the heat sinks. Insufficient contact, incorrect types of heat sinks, fans, or thermal compound used or improper amount of thermal compound applied on the CPU die can cause the processors to overheat, which may crash the system.

The Retention Module can prevent the board to crooked, so user must add the Retention Module to hold up the weight of Heat Sink & Fan.

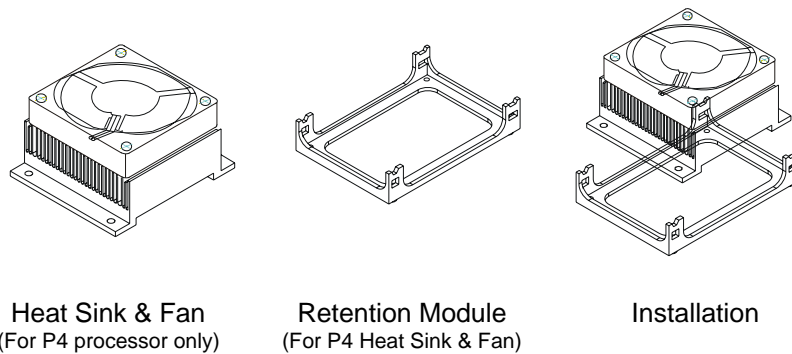

Figure 4: Heat Sink Installation

### 2.1.3 Memory Module Installation

Figure 5 display the notch marks and what they should look like on your DIMM memory module.

DIMMs have 184-pins and two notches, that will match with the onboard DIMM socket. DIMM modules are installed by placing the chip firmly into the socket at a 90-degree angle and pressing straight down (figure 6) until it fits tightly into the DIMM socket.

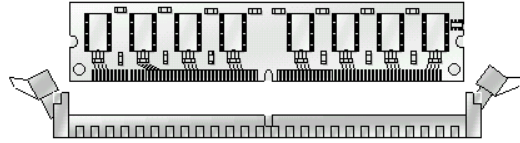

Figure 5: DIMM Memory and 184-pins Socket

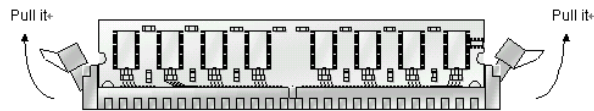

Figure 6: Memory Installation

Carefully follow the steps below in order to install the DIMMs:

1. To avoid generating static electricity and damaging the DIMM, ground yourself by touching a grounded metal surface or using a ground scrap before you touch the DIMM.
2. Do not touch the connector of the DIMM. Dirt residue may cause a malfunction.
3. Hold the DIMM with its notch to the front side of the IP-4PGP23 Series and insert it completely into the socket. A DIMM should be inserted into the inner socket first. Guiding the hole at each end of the DIMM over the retaining post at each end of the DIMM socket.
4. If you install two DIMMs, install the second DIMM using the same procedure as above.

5. If DIMM does not go in smoothly, do not force it. Pull it all the way out and try again.
6. Make sure the DIMM is properly installed and locked by the tabs on both sides of the socket.

**Removing a DIMM:**

To remove the DIMM, use your fingers or a small screwdriver to carefully push away the plastic tabs that secure the DIMM at each end. Lift it out of the socket.

**Make sure you store the DIMM in an anti-static bag and must be populated the same size and manufactory of memory modules. .**

**2.1.4 Setting Jumpers**

There are jumpers on the system board of the system board. You can set the jumpers to make the necessary operations.

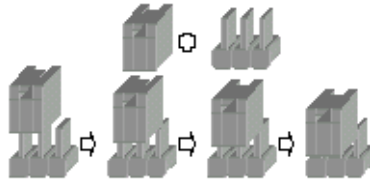
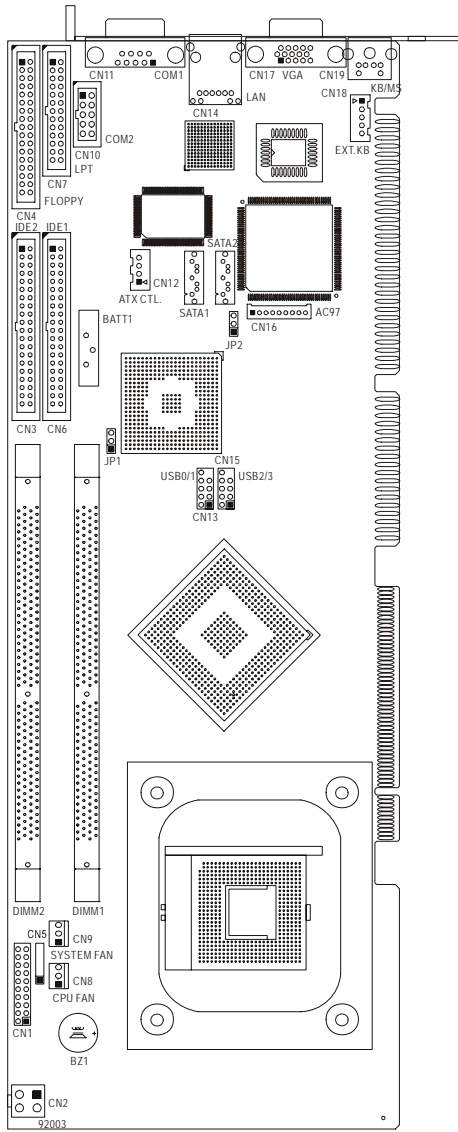

Figure 7: Jumper Connector

For any three-pins jumpers (figure 7), the jumper setting is 1-2 when the jumper connects pin 1 and 2. The setting is 2-3 when pin 2 and 3 are connected and so on. You see one of the lines surrounding jumpers is thick, which indicates pin NO.1.

To move a jumper from one position to another, use needle-nose pliers or tweezers to pull the pin cap off the pin and move it to the desired position.

## 2.2 Board Layout Jumper & Connector Location



## 2.3 Jumper Setting

### Table for Jumper Location Description:

Use the information in the following table to change the jumpers.

Jumpers	Functions
JP1	Clear CMOS setting select
JP2	Watchdog Timer setting select

In order to set up the correct configuration, here is the description about how to set the jumpers to enable/disable or change functions. All jumpers' location please refer to jumper location diagram.

#### ◆ Clear CMOS setting select: JP1

Function	JP1
Normal (Default)	1-2
Clear CMOS	2-3

##### • Location:

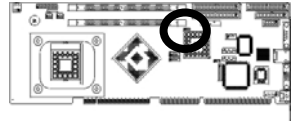

#### ◆ Watchdog Timer setting select: JP2

Function	JP2
NMI	1-2
Reset System (Default)	2-3

##### • Location:

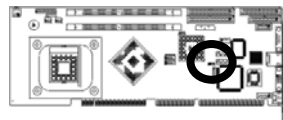

## 2.4 Connector's Description Connector Location

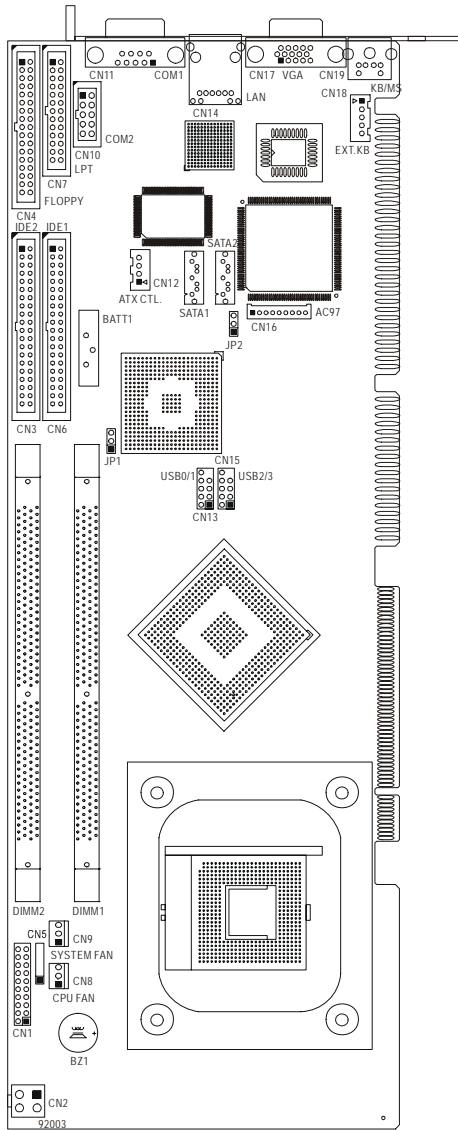

**Table for Connector's Location Description:**

Use the information in the following table to change the connector.

<b>Connectors</b>	<b>Functions</b>
CN1	System panel indicate connector
CN2	ATX 12V power connector
CN3	Secondary IDE connector
CN4	Floppy disk connector
CN5	IrDA connector
CN6	Primary IDE connector
CN7	Parallel port connector
CN8	CPU fan connector
CN9	System fan connector
CN10	COM2 RS-232 serial port connector
CN11	COM1 RS-232 serial port connector
CN12	ATX control power connector
CN13	USB 0/1 (pin-header) connector
CN14	Gigabit LAN (82547GI) RJ-45 connector
CN15	USB 2/3 (pin-header) connector
CN16	Extension Audio (pin-header) connector
CN17	CRT VGA port connector
CN18	External keyboard connector
CN19	PS/2 keyboard or mouse connector
SATA1	S-ATA1 connector
SATA2	S-ATA2 connector

◆ System panel indicate connector: CN1

Pin #	Assignment	Pin #	Assignment
<b>PWR_LED</b>		<b>SPEAKER</b>	
1	+5V	2	SPKR (Default)
3	NC	4	BUZZ (Default)
5	PWLED (Ground)	6	NC
<b>KEYLOCK</b>		8	+5V
7	KBLOCK	<b>RESET</b>	
9	Ground	10	RESET
<b>ATX_PWR_ON</b>		12	Ground
11	Ground	<b>HD_LED</b>	
13	NC	14	HDDLED
15	PSON	16	+5V
17	5VSB	<b>PWR_ON</b>	
19	---	18	PWRBT+ (5VSB)
		20	PWRBT-

• Figure:

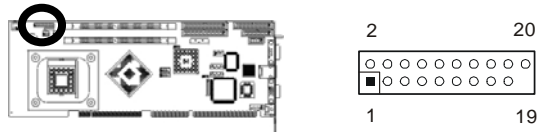

◆ ATX 12V power connector: CN2

Pin #	Assignment	Pin #	Assignment
1	Ground	3	+12V
2	Ground	4	+12V

• Figure:

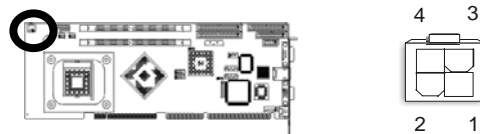

◆ **Secondary IDE connector (40-pins 2.54mm pitch pin-header with housing): CN3**

Pin #	Assignment	Pin #	Assignment
1	Reset IDE	2	Ground
3	IDE Data 7	4	IDE Data 8
5	IDE Data 6	6	IDE Data 9
7	IDE Data 5	8	IDE Data 10
9	IDE Data 4	10	IDE Data 11
11	IDE Data 3	12	IDE Data 12
13	IDE Data 2	14	IDE Data 13
15	IDE Data 1	16	IDE Data 14
17	IDE Data 0	18	IDE Data 15
19	Ground	20	---
21	DRQ 1	22	Ground
23	Host IOW	24	Ground
25	Host IOR	26	Ground
27	IOCHRDY	28	Host ALE
29	DACK 1	30	Ground
31	IRQ 15	32	No Connect
33	Address 1	34	Ground
35	Address 0	36	Address 2
37	Chip Select 0	38	Chip Select 1
39	Activity	40	Ground

• **Figure:**

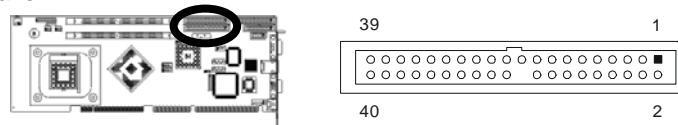

◆ Floppy disk connector (34-pins 2.54mm pitch pin-header with housing): CN4

Pin #	Assignment	Pin #	Assignment
1	Ground	2	Drive Density Selection
3	Ground	4	No Connect
5	Ground	6	Drive Density Selection
7	Ground	8	Index
9	Ground	10	Motor Enable 0
11	Ground	12	Drive Select 1
13	Ground	14	Drive Select 0
15	Ground	16	Motor Enable 1
17	Ground	18	Direction
19	Ground	20	Step
21	Ground	22	Write Data
23	Ground	24	Write Gate
25	Ground	26	Track 00
27	Ground	28	Write Protect
29	Ground	30	Read Data
31	Ground	32	Head Select
33	Ground	34	Diskette Change

• Figure:

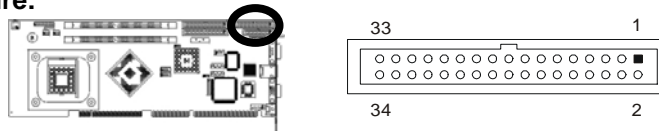

◆ IrDA connector: CN5

Pin #	Assignment
1	+5V
2	FIRTX
3	IRRX
4	Ground
5	IRTX

• Figure:

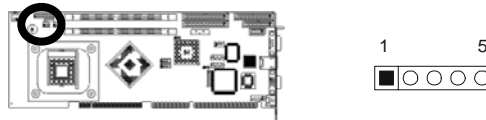

◆ **Primary IDE connector (40-pins 2.54mm pitch pin-header with housing): CN6**

Pin #	Assignment	Pin #	Assignment
1	Reset IDE	2	Ground
3	IDE Data 7	4	IDE Data 8
5	IDE Data 6	6	IDE Data 9
7	IDE Data 5	8	IDE Data 10
9	IDE Data 4	10	IDE Data 11
11	IDE Data 3	12	IDE Data 12
13	IDE Data 2	14	IDE Data 13
15	IDE Data 1	16	IDE Data 14
17	IDE Data 0	18	IDE Data 15
19	Ground	20	---
21	DRQ 0	22	Ground
23	Host IOW	24	Ground
25	Host IOR	26	Ground
27	IOCHRDY	28	Host ALE
29	DACK 0	30	Ground
31	IRQ 14	32	No Connect
33	Address 1	34	Ground
35	Address 0	36	Address 2
37	Chip Select 0	38	Chip Select 1
39	Activity	40	Ground

• **Figure:**

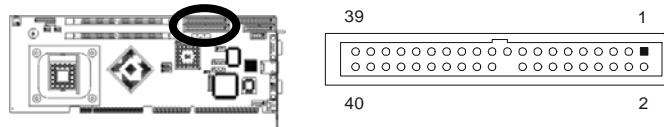

◆ **Parallel port connector (26-pins 2.54mm pitch pin-header with housing): CN7**

Pin #	Assignment	Pin #	Assignment
1	Line Printer Strobe	2	Auto Feed
3	PD 0, Parallel Data 0	4	Error
5	PD 1, Parallel Data 1	6	Initialize
7	PD 2, Parallel Data 2	8	Select
9	PD 3, Parallel Data 3	10	Ground
11	PD 4, Parallel Data 4	12	Ground
13	PD 5, Parallel Data 5	14	Ground
15	PD 6, Parallel Data 6	16	Ground
17	PD 7, Parallel Data 7	18	Ground
19	ACK, Acknowledge	20	Ground
21	Busy	22	Ground
23	Paper Empty	24	Ground
25	Select	26	NC

• **Figure:**

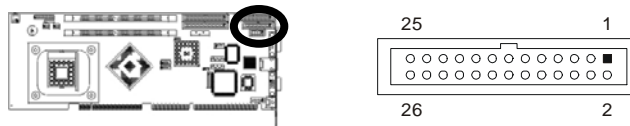

◆ **CPU fan connector: CN8**

Pin #	Assignment
1	Ground
2	+12V
3	Fan Status Signal

• **Figure:**

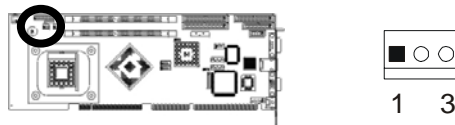

◆ System fan connector: CN9

Pin #	Assignment
1	Ground
2	+12V
3	Fan Status Signal

• Figure:

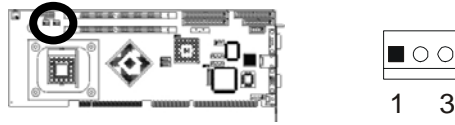

◆ COM2 RS-232 serial port connector (10-pins 2.54mm pitch pin-header with housing): CN10

Pin #	Assignment	Pin #	Assignment
1	DCD (Data Carrier Detect)	2	DSR (Data Set Ready)
3	RXD (Receive Data)	4	RTS (Request to Send)
5	TXD (Transmit Data)	6	CTS (Clear to Send)
7	DTR (Data Terminal Ready)	8	RI (Ring Indicator)
9	Ground	10	Ground

• Figure:

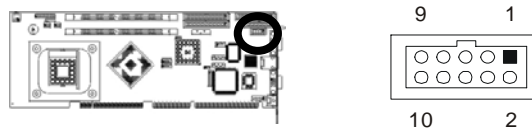

◆ **COM1 RS-232 serial port connector (D-Sub 9-pins male): CN11**

Pin #	Assignment	Pin #	Assignment
1	DCD (Data Carrier Detect)	6	DSR (Data Set Ready)
2	RXD (Receive Data)	7	RTS (Request to Send)
3	TXD (Transmit Data)	8	CTS (Clear to Send)
4	DTR (Data Terminal Ready)	9	RI (Ring Indicator)
5	Ground		

• **Figure:**

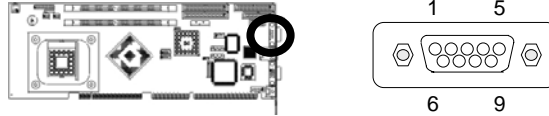

◆ **ATX control power connector: CN12**

Pin #	Assignment
1	PME
2	5VSB
3	PWRON
4	Ground

• **Figure:**

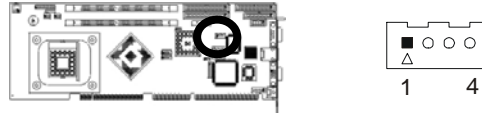

◆ **USB 0/1 connector (10-pins pin-header): CN13**

Pin #	Assignment	Pin #	Assignment
1	VCC	2	VCC
3	USB0 -	4	USB1 -
5	USB0 +	6	USB1 +
7	Ground	8	Ground
9	---	10	NC

• **Figure:**

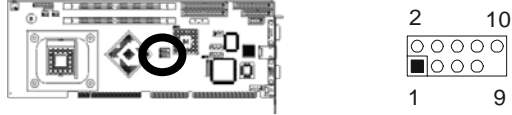

◆ **Gigabit LAN (82547GI) RJ-45 connector (RJ-45 phone-jacket): CN14**

Pin #	Assignment	Pin #	Assignment
1	Transmit output (+)	5	NC
2	Transmit output (-)	6	Receive input (-)
3	Receive input (+)	7	NC
4	NC	8	NC

• **Figure:**

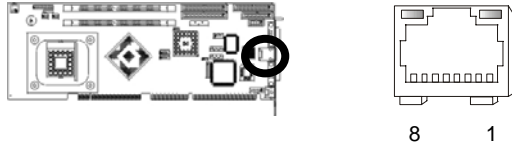

◆ **USB 2/3 connector (10-pins pin-header): CN15**

Pin #	Assignment	Pin #	Assignment
1	VCC	2	VCC
3	USB2 -	4	USB3 -
5	USB2 +	6	USB3 +
7	Ground	8	Ground
9	---	10	NC

• **Figure:**

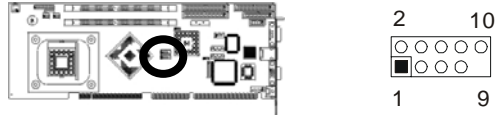

◆ **Extension Audio connector (9-pins pin-header): CN16**

Pin #	Assignment
1	+12V
2	3.3V
3	AC_SYNC
4	AC_SDOUT
5	Ground
6	AC_BCLK
7	Ground
8	AC_RST#
9	AC_SDIN0

• **Figure:**

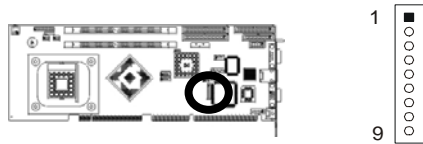

◆ CRT VGA port connector (D-SUB 15-pins female): CN17

Pin #	Assignment	Pin #	Assignment
1	Red Color Signal	2	Green Color Signal
3	Blue Color Signal	4	5V
5	Ground	6	Ground
7	Ground	8	Ground
9	5V	10	Ground
11	5V	12	VGA DDA
13	H-Sync.	14	V-Sync.
15	SPCLK		

• Figure:

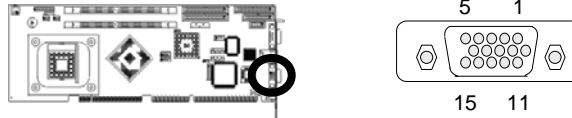

◆ External keyboard connector (5-pins): CN18

Pin #	Assignment
1	Keyboard Clock
2	Keyboard Data
3	NC
4	Ground
5	VCC

• Figure:



◆ **PS/2 keyboard or mouse connector (Mini Din 6 pins): CN19**

Pin #	Assignment	Pin #	Assignment
1	Keyboard Data	2	Mouse Data
3	Ground	4	+5V
5	Keyboard Clock	6	Mouse Clock

• **Figure:**

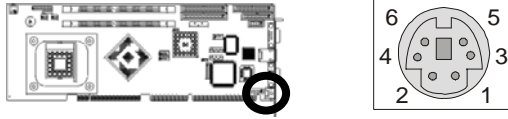

◆ **S-ATA1 connector (7-pins): SATA1**

Pin #	Assignment
1	Ground
2	SATA1_TXP
3	SATA1_TXN
4	Ground
5	SATA1_RXN
6	SATA1_RXP
7	Ground

• **Figure:**

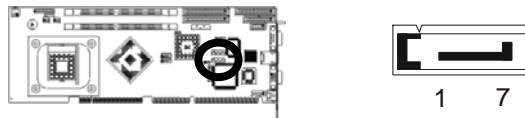

## ◆ S-ATA2 connector (7-pins): SATA2

Pin #	Assignment
1	Ground
2	SATA2_TXP
3	SATA2_TXN
4	Ground
5	SATA2_RXN
6	SATA2_RXP
7	Ground

## • Figure:

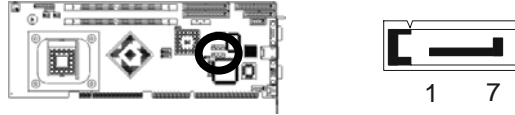

## 2.5 Optional IP-ALCS20 Audio Card Board Location:

Thank you for select IP-ALCS20 Audio Card, here is the description about how to connect the connector and phone jack to use audio functions.

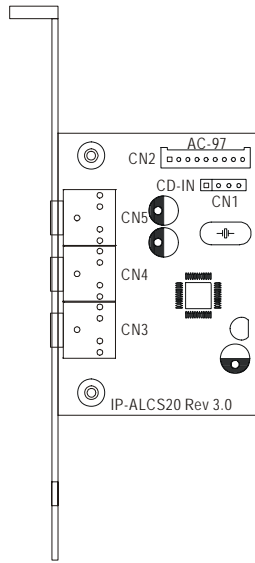

1. Check the contents of the packing:

◆ IP-ALCS20 Audio Card

◆ Audio 9-pins round cable

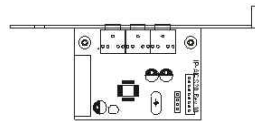

## 2. Table for Audio Card Description of Connector:

Connectors	Functions
CN1	CD_IN connector
CN3, CN4, CN5	Audio Line_out, Line_in, MIC phone jack
CN2	Audio signal connector

## 3. Description of Connector:

## ◆ CD\_IN connector: JP1

Pin #	Assignment
1	Left
2	Ground
3	Ground
4	Right

## ◆ Audio Line\_out, Line\_in, MIC phone jack: CN3, CN4, CN5

Pin #	Assignment
CN3 (Green)	Line_out
CN4 (Blue)	Line_in
CN5 (Red)	MIC

## ◆ Audio signal connector (9-pins): CN2

Pin #	Assignment
1	+12V
2	3.3V
3	AC_SYNC
4	AC_SDOOUT
5	Ground
6	AC_BCLK
7	Ground
8	AC_RST#
9	AC_SDIN0

A graphic consisting of three overlapping rectangular boxes, with the text 'SECTION 3' centered in the front-most box.

## SECTION 3

### **AWARD BIOS SETUP**

#### **3.1 BIOS Instructions**

Award's ROM BIOS provides a built-in Setup program, which allows user to modify the basic system configuration and hardware parameters. The modified data will be stored in a battery-backed CMOS, so that data will be retained even when the power is turned off. In general, the information saved in the CMOS RAM will stay unchanged unless there is a configuration change in the system, such as hard drive replacement or a device is added.

It is possible for the CMOS battery to fail, this will cause data loss in the CMOS only. If this does happen you will need to reconfigure your BIOS settings.

### 3.2 Main Menu

Once you enter the AwardBIOS™ CMOS Setup Utility, the Main Menu will appear on the screen. The Main Menu allows you to select from several setup functions and two exit choices. Use the arrow keys to select among the items and press <Enter> to accept and enter the sub-menu.

Phoenix - AwardBIOS CMOS Setup Utility	
<ul style="list-style-type: none"> <li>➤Standard CMOS Feature</li> <li>➤Advanced BIOS Feature</li> <li>➤Advanced Chipset Feature</li> <li>➤Integrated Peripherals</li> <li>➤Power Management Setup</li> <li>➤PnP/PCI Configurations</li> <li>➤PC Health Status</li> </ul>	<ul style="list-style-type: none"> <li>➤Frequency/Voltage Control</li> <li>Load Fail-Safe Defaults</li> <li>Load Optimized Defaults</li> <li>Set Supervisor Password</li> <li>Set User Password</li> <li>Save &amp; Exit Setup</li> <li>Exit Without Saving</li> </ul>
Esc: Quit	↑ ↓ → ←: Select Item
F10: Save & Exit Setup	
Time, Date, Hard Disk Type....	

Note: that a brief description of each highlighted selection appears at the bottom of the screen.

#### Setup Items:

The main menu includes the following main setup categories. Recall that some systems may not include all entries.

#### Standard CMOS Features:

Use this menu for basic system configuration. See section 3.3 for the details.

#### Advanced BIOS Features:

Use this menu to set the Advanced Features available on your system. See section 3.5 for the details.

#### Advanced Chipset Features:

Use this menu to change the values in the chipset registers and optimize your system's performance. See section 3.6 for the details.

**Integrated Peripherals:**

Use this menu to specify your settings for integrated peripherals. See section 3.7 for the details.

**Power Management Setup:**

Use this menu to specify your settings for power management. See section 3.8 for the details.

**PnP / PCI Configuration:**

This entry appears if your system supports PnP / PCI. See section 3.9 for the details.

**PC Health Status:**

Use this menu to show your system temperature, speed and voltage status. See section 3.10 for the details.

**Frequency / Voltage Control:**

Use this menu to specify your settings for frequency/voltage control. See section 3.11 for the details.

**Load Fail-Safe Defaults:**

Use this menu to load the BIOS default values for the minimal/stable performance for your system to operate. See section 3.12 for the details.

**Load Optimized Defaults:**

Use this menu to load the BIOS default values that are factory settings for optimal performance system operations. While Award has designed the custom BIOS to maximize performance, the factory has the right to change these defaults to meet their needs. See section 3.13 for the details.

**Supervisor / User Password:**

Use this menu to set User and Supervisor Passwords. See section 3.14 for the details.

**Save & Exit Setup:**

Save CMOS value changes to CMOS and exit setup. See section 3.15 for the details.

**Exit Without Save:**

Abandon all CMOS value changes and exit setup. See section 3.15 for the details.

### 3.3 Standard CMOS Features

The items in Standard CMOS Setup Menu are divided into 10 categories. Each category includes no, one or more than one setup items. Use the arrow keys to highlight the item and then use the <PgUp> or <PgDn> keys to select the value you want in each item.

Standard CMOS Features		Item Help
Date (mm:dd:yy):	Wed, Aug 9 2006	
Time (hh:mm:ss):	16:19:20	
➤ IDE Channel 0 Master	13579 MB	Menu Level ➤
➤ IDE Channel 0 Slave	None	
➤ IDE Channel 1 Master	None	Change the day, month, year and century
➤ IDE Channel 1 Slave	None	
*** On-Chip Serial ATA Channel***		
➤ Channel 2	None	
➤ Channel 3	None	
Drive A	1.44M, 3.5 in.	
Drive B	None	
Video	EGA/VGA	
Halt On	All, but keyboard	
Based Memory	640K	
Extended Memory	1039360K	
Total Memory	1048384K	
↑↓→← Move   Enter: Select   +/-/PU/PD: Value   F10: Save   ESC: Exit   F1: General Help F5: Previous Values   F6: Fail-safe defaults   F7: Optimized Defaults		

**Date:** Options Month/DD/YYYY

Set the system date. Note that the 'Day' automatically changes when you set the date.

**Time:** Options HH : MM : SS

Set the system time.

**IDE Channel 0 Master:** Options are in its sub menu (described in 3.4)

Press <Enter> to enter the sub menu of detailed options.

**IDE Channel 0 Slave:** Options are in its sub menu (described in 3.4)

Press <Enter> to enter the sub menu of detailed options.

**IDE Channel 1 Master:** Options are in its sub menu (described in 3.4)  
Press <Enter> to enter the sub menu of detailed options.

**IDE Channel 1 Slave:** Options are in its sub menu (described in 3.4)  
Press <Enter> to enter the sub menu of detailed options.

**Channel 2:** Options are in its sub menu (described in 3.4)  
Press <Enter> to enter the sub menu of detailed options.

**Channel 3:** Options are in its sub menu (described in 3.4)  
Press <Enter> to enter the sub menu of detailed options.

**Drive A / Drive B:** Options None 360K, 5.25 in/1.2M, 5.25 in/720K, 3.5 in/  
1.44M, 3.5 in/2.88M, 3.5 in  
Select the type of floppy disk drive installed in your system.

**Video:** Options EGA/VGA/CGA 40/CGA 80/MONO  
Select the default video device.

**Halt On:** Options All Errors/No Errors/All, but Keyboard/All, but Diskette/All,  
but Disk/Key  
Select the situation in which you want the BIOS to stop the POST process  
and notify you.

**Base Memory:**  
Displays the amount of conventional memory detected during boot up.

**Extended Memory:**  
Displays the amount of extended memory detected during boot up.

**Total Memory:**  
Displays the total memory available in the system.

### 3.4 IDE Adapters

The IDE adapters control the hard disk drive. Use a separate sub menu to configure each hard disk drive.

Phoenix - AwardBIOS CMOS Setup Utility		
IDE Channel 0 Master		
IDE HDD Auto-Detection	Press Enter	Item Help
IDE Channel 0 Master Access Mode	Auto Auto	Menu Level >>
Capacity	13579 MB	To auto-detect the HDD's size, head... on this channel
Cylinder	26310	
Head	16	
Precomp	0	
Landing Zone	26309	
Sector	63	
↑↓→← Move Enter: Select +/-/PU/PD: Value F10: Save ESC: Exit F1: General Help F5: Previous Values F6: Fail-safe defaults F7: Optimized Defaults		

#### IDE HDD Auto-detection: Options Press Enter

Press Enter to auto-detect the HDD on this channel. If detection is successful, it fills the remaining fields on this menu.

#### IDE Channel 0 Master: Options None, Auto and Manual

Selecting "Manual" lets you set the remaining fields on this screen. Selects the type of fixed disk. "User Type" will let you select the number of cylinders, heads, etc. Note: PRECOMP=65535 means NONE !

#### Access Mode: Options CHS, LBA, Large and Auto

Choose the access mode for this hard disk

#### Capacity: Options Auto Display your disk drive size

Disk drive capacity (Approximated). Note that this size is usually slightly greater than the size of a formatted disk given by a disk-checking program.

The following options are selectable only if the 'IDE Primary Master' item is set to 'Manual'

**Cylinder:** Options Min = 0, Max = 65535  
Set the number of cylinders for this hard disk.

**Head:** Options Min = 0, Max = 255  
Set the number of read/write heads

**Precomp:** Options Min = 0, Max = 65535  
\*\*\*\* **Warning:** Setting a value of 65535 means no hard disk

**Landing zone:** Options Min = 0, Max = 65535

**Sector:** Options Min = 0, Max = 255  
Number of sectors per track

### 3.5 Advanced BIOS Features

This section allows you to configure your system for basic operation. You have the opportunity to select the system's default speed, boot-up sequence, keyboard operation, shadowing and security.

Phoenix - AwardBIOS CMOS Setup Utility		
Advanced BIOS Features		
<ul style="list-style-type: none"> <li>&gt; CPU Feature <span style="float: right;">Press Enter</span></li> <li>Virus Warning <span style="float: right;">Disabled</span></li> <li>Hyper-Threading Technology <span style="float: right;">Enabled</span></li> <li>Quick Power On Self Test <span style="float: right;">Enabled</span></li> <li>Boot Up NumLock Status <span style="float: right;">On</span></li> <li>Gate A20 Option <span style="float: right;">Fast</span></li> <li>Typematic Rate Setting <span style="float: right;">Disabled</span></li> <li>X Typematic Rate (Chars/Sec) <span style="float: right;">6</span></li> <li>X Typematic Delay (Msec) <span style="float: right;">250</span></li> <li>Security Option <span style="float: right;">Setup</span></li> <li>X APIC Mode <span style="float: right;">Enabled</span></li> <li>MPS Version Control For OS <span style="float: right;">1.4</span></li> <li>OS Select For DRAM &gt; 64MB <span style="float: right;">Non-OS2</span></li> <li>&gt; Cache Setup <span style="float: right;">Press Enter</span></li> <li>&gt; Boot Seq &amp; Floppy Setup <span style="float: right;">Press Enter</span></li> <li>&gt; Console Redirection <span style="float: right;">Press Enter</span></li> </ul>		Item Help
Menu Level >		
↑↓→←Move Enter: Select +/-/PU/PD: Value F10: Save ESC: Exit F1: General Help F5: Previous Values F6: Fail-safe defaults F7: Optimized Defaults		

#### CPU Feature:

Phoenix - AwardBIOS CMOS Setup Utility		
CPU Feature		
<ul style="list-style-type: none"> <li>Delay Prior to Thermal <span style="float: right;">16Min</span></li> <li>Thermal Management <span style="float: right;">Thermal Monitor 1</span></li> <li>LIMIT CPUID MaxVal <span style="float: right;">Disabled</span></li> </ul>		Item Help
Menu Level >>		
↑↓→←Move Enter: Select +/-/PU/PD: Value F10: Save ESC: Exit F1: General Help F5: Previous Values F6: Fail-safe defaults F7: Optimized Defaults		

#### Delay Prior To Thermal:

Select this item allows the delay prior to thermal time.

The Choice: Auto, 4, 8, 16, 32Min

#### Thermal Management:

It shows you the thermal Monitor.

**LIMIT CPUID MaxVal:**

This item should be disabled for WinXp, but enabled for NT4.0.

**Virus Warning:**

Allow you to choose the VIRUS Warning feature for IDE Hard Disk boot sector protection. If this function is enabled and someone attempts to write data into this area, BIOS will show a warning message on screen and alarm beep.

Enabled---Activates automatically when the system boots up causing a warning message to appear when anything attempts to access the boot sector or hard disk partition table.

Disabled---No warning message will appear when anything attempts to access the boot sector or hard disk partition table.

**Hyper-Threading Technology:**

Allow you to choose the CPU Hyper-Threading Technology.

The choice: Enabled, Disabled.

**Quick Power On Self Test:**

This category speeds up Power On Self Test (POST) after you power up the computer. If it is set to Enable, BIOS will shorten or skip some check items during POST.

The choice: Enabled, Disabled.

**Boot Up NumLock Status:**

Select power on state for NumLock.

The choice: On, Off

**Gate A20 Option:**

Select if chipset or keyboard controller should control GateA20.

Normal---A pin in the keyboard controller controls GateA20

Fast---Lets chipset control GateA20

**Typematic Rate Setting:**

Keystrokes repeat at a rate determined by the keyboard controller. When enabled, the typematic rate and typematic delay can be selected.

The choice: Enabled, Disabled.

**Typematic Rate (Chars/Sec):**

Sets the number of times a second to repeat a keystroke when you hold the key down.

The choice: 6, 8, 10, 12, 15, 20, 24 and 30.

**Typematic Delay (Msec):**

Sets the delay time after the key is held down before it begins to repeat the keystroke.

The choice: 250, 500, 750 and 1000.

**Security Option:**

Select whether the password is required every time the system boots or only when you enter setup.

System---The system will not boot and access to Setup will be denied if the correct password is not entered at the prompt.

Setup---The system will boot, but access to Setup will be denied if the correct password is not entered at the prompt.

Note: To disable security, select PASSWORD SETTING at Main Menu and then you will be asked to enter password. Do not type anything and just press <Enter>, it will disable security. Once the security is disabled, the system will boot and you can enter Setup freely.

**APIC Mode:**

This item shows you to enable/disable APIC Mode.

**MPS Version Control For OS:**

Select the operating system that is Multi-Processors Version Control for OS.

The choice: 1.4, 1.1.

**OS Select For DRAM > 64MB:**

Select the operating system that is running with greater than 64MB of RAM on the system.

The choice: Non-OS2, OS2.

**Cache Setup:**

Phoenix - AwardBIOS CMOS Setup Utility

Cache Setup

CPU L1 & L2 Cache <b>Enabled</b>	Item Help <hr/> Menu Level    >>
↑↓→← Move    Enter: Select    +/-/PU/PD: Value    F10: Save    ESC: Exit    F1: General Help F5: Previous Values    F6: Fail-safe defaults    F7: Optimized Defaults	

**CPU L1& L2 Cache:**

These two categories speed up memory access. However, it depends on CPU and chipset designed.

The Choice: Enabled, Disabled.

**Boot Seq & Floppy Setup:**

Phoenix - AwardBIOS CMOS Setup Utility  
 Boot Seq & Floppy Setup

> Hard Disk Boot Priority First Boot Device Second Boot Device Third Boot Device Boot Other Device  Swap Floppy Drive Boot Up Floppy Seek Report No FDD For WIN95	Press Enabled Floppy Hard Disk LS120 Enabled  Disabled Enabled No	Item Help <hr/> Menu Level >>
↑↓→← Move    Enter: Select    +/-/PU/PD: Value    F10: Save    ESC: Exit    F1: General Help F5: Previous Values    F6: Fail-safe defaults    F7: Optimized Defaults		

**Hard Disk Boot Priority:**

Press Enter and It shows you the hard disk boot priority.

**First/Second/Third Boot Device:**

The BIOS attempts to load the operating system from the devices in the sequence selected in these items.

The Choice: Floppy, LS/ZIP, Hard Disk, SCSI, CDROM, LAN and Disabled.

**Boot Other Device:**

When enabled, the system searches all other possible locations for an operating system if it fails to find one in the devices specified under the first, second, and third boot devices.

The Choice: Enabled, Disabled.

**Swap Floppy Drive:**

This item allows you to disable or enabled swap floppy drive.

The Choice: Enabled, Disabled.

**Boot Up Floppy Seek:**

Seeks disk drives during boot up. Disabling speeds boot up.  
The choice: Enabled, Disabled.

**Report No FDD For WIN95:**

Whether report no FDD for Win 95 or not.  
The choice: Yes, No.

**Console Redirection:**

Phoenix - AwardBIOS CMOS Setup Utility

Console Redirection

Console Redirection	Disabled	Item Help
X Baud Rate	19200	
Agent Connect via	NULL	
Agent wait time (min)	1	Menu Level >>
Agent after boot	Disabled	Enabled – Attempt to redirect console via COM port
		Disabled – Attempt to redirect console when keyboard absent
↑↓→←Move Enter: Select +/-PU/PD: Value F10: Save ESC: Exit F1: General Help F5: Previous Values F6: Fail-safe defaults F7: Optimized Defaults		

**Console Redirection:**

This item allows you to redirect console.  
The choice: Enabled---Redirect console via Com Port.  
Disabled---Redirect console when keyboard absent.

**Baud Rate:**

This item specifies baud rate of console redirection.  
The choice: 9600, 19200, 38400, 57600, 115200.

**Agent Connect via:**

Select Null let agent connect directly.

**Agent wait time (min):**

Select the time to allow agent connects when timeout.  
The choice: 1, 2, 4, 8.

**Agent after boot:**

This item allows you to keep agent running after OS boot.  
The Choice: Enabled, Disabled.

### 3.6 Advanced Chipset Features

This section allows you to configure the system based on the specific features of the installed chipset. This chipset manages bus speeds and access to system memory resources, such as DRAM and the external cache. It also coordinates communications between the conventional ISA bus and the PCI bus. It must be stated that these items should never need to be altered. The default settings have been chosen because they provide the best operating conditions for your system. The only time you might consider making any changes would be if you discovered that data was being lost while using your system.

#### Phoenix - AwardBIOS CMOS Setup Utility

##### Advanced Chipset Features

		Item Help
DRAM Timing Selectable	By SPD	
X CAS Latency Time	3	
X Active to Precharge Delay	8	
X DRAM RAS# to CAS# Delay	3	Menu Level >
X DRAM RAS# Precharge	3	
Memory Frequency For	Auto	
System BIOS Cacheable	Enabled	
Video BIOS Cacheable	Disabled	
Memory Hole At 15M-16M	Disabled	
AGP Aperture Size (MB)	128	
Init Display First	Onboard/AGP.	
**On-Chip VGA Setting**		
On-Chip VGA	Enabled	
On-Chip Frame Buffer Size	8MB	
↑↓→←Move Enter: Select +/-/PU/PD: Value F10: Save ESC: Exit F1: General Help F5: Previous Values F6: Fail-safe defaults F7: Optimized Defaults		

#### DRAM Timing Selectable:

Select the operating system that is selecting DRAM timing, so select SPD for setting SDRAM timing by SPD.

The choice: Manual, By SPD.

**CAS Latency Time:**

When synchronous DRAM is installed, the number of clock cycles of CAS latency depends on the DRAM timing.

The choice: 2, 2.5 and 3.

**Active To Precharge Delay:**

Select the operating system that is active to precharge delay.

The choice: 5, 6, 7, 8.

**DRAM RAS# to CAS# Delay:**

You can select RAS to CAS Delay time in HCLKs of 2/2 or 3/3.

The system board designer should set the values in this field, depending on the DRAM installed. Do not change the values in this field unless you change specifications of the installed DRAM or the installed CPU.

The choice: 2, 3, 4.

**DRAM RAS# Precharge:**

If an insufficient number of cycles are allowed for the RAS to accumulate its charge before DRAM refresh, the refresh may be incomplete and the DRAM may fail to retain data. Fast gives faster performance; and Slow gives more stable performance. This field applies only when synchronous DRAM is installed in the system.

The choice: 2, 3, 4.

**Memory Frequency For:**

You can use this item to select operating frequency for the main system memory.

The choice: Auto, DDR266, DDR320, DDR400.

**System BIOS Cacheable:**

Selecting "Enabled" allows caching of the system BIOS ROM at F0000h-FFFFFh, resulting in better system performance. However, if any program writes to this memory area, a system error may result.

The choice: Enabled, Disabled.

**Video BIOS Cacheable:**

Select "Enabled" allows caching of the video BIOS, resulting in better system performance. However, if any program writes to this memory area, a system error may result.

The choice: Enabled, Disabled.

**Memory Hole At 15M-16M:**

You can reserve this area of system memory for ISA adapter ROM. When this area is reserved, it cannot be cached. The user information of peripherals that need to use this area of system memory usually discusses their memory requirements.

The choice: Enabled, Disabled.

**AGP Aperture Size (MB):**

This field determines the effective size of the Graphic Aperture used for a particular GMCH configuration. It can be updated by the GMCH-specific BIOS configuration sequence before the PCI standard bus enumeration sequence takes place. If it is not updated then a default value will select an aperture of maximum size.

The choice: 4, 8, 16, 32, 64, 128 and 256.

**Init Display First:**

This item allows you to decide to active whether PCI Slot or on-chip VGA first.

The choice: PCI Slot, Onboard/AGP.

**On-Chip VGA:**

You can use this item to select on-chip VGA for the main system VGA.

The choice: Enabled, Disabled.

**On-Chip Frame Buffer Size:**

You can use this item to select frame buffer size.

The choice: 1MB, 8MB, 16Mb.

### 3.7 Integrated Peripherals

Phoenix - AwardBIOS CMOS Setup Utility  
Integrated Peripherals

> OnChip IDE Device            Press Enter > Onboard Device                Press Enter Onboard Lan Boot ROM       Disabled > Onboard I/O Chip Setup       Press Enter	Item Help <hr/> Menu Level >
↑↓→←Move Enter: Select +/-/PU/PD: Value F10: Save ESC: Exit F1: General Help F5: Previous Values F6: Fail-safe defaults F7: Optimized Defaults	

#### OnChip IDE Device:

OnChip IDE Device

IDE HDD Block Mode            Enabled On-Chip Primary PCI IDE       Enabled IDE Primary Master PIO        Auto IDE Primary Slave PIO         Auto IDE Primary Master UDMA       Auto IDE Primary Slave UDMA       Auto On-Chip Secondary PCI IDE     Enabled IDE Secondary Master PIO      Auto IDE Secondary Slave PIO       Auto IDE Secondary Master UDMA    Auto IDE Secondary Slave UDMA     Auto  *****On-Chip Serial ATA Setting On-Chip Serial ATA            Enhanced Mode Serial ATA Conn.1              Channel 2 Serial ATA Conn.2              Channel 3	Item Help <hr/> Menu Level >  If you IDE hard drive supports block mode select Enabled for automatic detection of the optimal number of block read/writes per sector the drive can support.
↑↓→←Move Enter: Select +/-/PU/PD: Value F10: Save ESC: Exit F1: General Help F5: Previous Values F6: Fail-safe defaults F7: Optimized Defaults	

#### IDE HDD Block Mode:

Block mode is also called block transfer, multiple commands, or multiple sector read/write. If your IDE hard drive supports block mode (most new drives do), select Enabled for automatic detection of the optimal number of block read/writes per sector the drive can support.

The choice: Enabled, Disabled

**OnChip Primary/Secondary PCI IDE:**

The integrated peripheral controller contains an IDE interface with support for two IDE channels. Select "Enabled" to activate each channel separately.

The choice: Enabled, Disabled.

**IDE Primary/Secondary Master/Slave PIO:**

The four IDE PIO (Programmed Input/Output) fields let you set a PIO mode (0-4) for each of the four IDE devices that the onboard IDE interface supports. Modes 0 through 4 provide successively increased performance. In Auto mode, the system automatically determines the best mode for each device.

The choice: Auto, Mode 0, Mode 1, Mode 2, Mode 3 and Mode 4.

**IDE Primary/Secondary Master/Slave UDMA:**

Ultra DMA/33 implementation is possible only if your IDE hard drive supports it and the operating environment includes a DMA driver (Windows 95 OSR2 or a third-party IDE bus master driver). If your hard drive and your system software both support Ultra DMA/33, select "Auto" to enable BIOS support.

The choice: Auto, Disabled.

**On-Chip Serial ATA:**

There are four Serial ATA fields let you set the Serial ATA.

Disabled---Disabled SATA Controller

Combined Mode---PATA and SATA are combined. Max. of 2 IDE drives in each channel.

Enhanced Mode---Enable both SATA and PATA. Max. of 6 IDE drives are supported.

SATA Only---SATA is operating in legacy mode.

**Serial ATA Port 0/1 Mode:**

This item allows you to select serial ATA Port 0/1 channel.

The choice: Channel 2, Channel 3.

**Onboard Device:**

Onboard Device		Item Help
USB Controller	Enabled	
USB 2.0 Controller	Enabled	
USB Keyboard Support	Disabled	
USB Mouse Support	Disabled	
AC97 Audio	Auto	
CSA LAN(Giga-LAN)	Enabled	
↑↓→← Move    Enter: Select    +/-/PU/PD: Value    F10: Save    ESC: Exit    F1: General Help F5: Previous Values    F6: Fail-safe defaults    F7: Optimized Defaults		Menu Level >

**USB Controller:**

Select "Enabled" if your system contains a Universal Serial Bus (USB) controller and you have USB peripherals.

The choice: Enabled, Disabled.

**USB 2.0 Controller:**

Select "Enabled" if your system contains a Universal Serial Bus 2.0 (USB 2.0) controller and you have USB peripherals.

The choice: Enabled, Disabled.

**USB Keyboard Support:**

Select "Enabled" if your system contains a Universal Serial Bus (USB) controller and you have a USB keyboard.

The choice: Enabled, Disabled.

**USB Mouse Support:**

Select "Enabled" if your system contains a Universal Serial Bus (USB) controller and you have a USB mouse.

The choice: Enabled, Disabled.

**AC97 Audio:**

This item allows you to decide to auto or disable the chipset family to support AC97 Audio.

The choice: Auto, Disabled.

**CSA LAN(Giga-LAN):**

Enables the onboard LAN feature.

**Onboard Lan Boot ROM:**

This item allows you to enable or disable the onboard LAN Boot ROM.  
The choice: Enabled, Disabled

**Onboard I/O Chip Setup:**

Onboard I/O Chip Setup

Onboard FDC Controller	Enabled	Item Help
Onboard Serial Port 1	3F8/IRQ4	
Onboard Serial Port 2	2F8/IRQ3	
UART Mode Select	Normal	Menu Level >
X RxD, TxD Active	Hi, Lo	
X IR Transmission Delay	Enabled	
X UR2 Duplex Mode	Half	
X Use IR Pins	IR-Rx2Tx2	
Onboard Parallel Port	378/IRQ7	
Parallel Port Mode	SPP	
X EPP Mode Select	EPP1.7	
X ECP Mode Use DMA	3	
PWRON After PWR-Fail	Off	
↑↓←→Move Enter: Select +/-/PU/PD: Value F10: Save ESC: Exit F1: General Help F5: Previous Values F6: Fail-safe defaults F7: Optimized Defaults		

**Onboard FDC Controller:**

Select "Enabled" if your system has a floppy disk controller (FDC) installed on the system board and you wish to use it. If you install and-in FDC or the system has no floppy drive, select Disabled in this field.

The choice: Enabled, Disabled.

**Onboard Serial Port 1/Port 2:**

Select an address and corresponding interrupt for the first and second serial ports.

The choice: 3F8/IRQ4, 2E8/IRQ3, 3E8/IRQ4, 2F8/IRQ3, Disabled and Auto.

**UART Mode Select:**

This item allows you to determine which Infra Red (IR) function of onboard I/O chip.

The Choice: Normal, IrDA and ASKIR.

**RxD, TxD Active:**

This item allows you to determine the active of RxD, TxD.  
The Choice: "Hi, Hi", "Lo, Lo", "Lo, Hi" and "Hi, Lo".

**IR Transmission Delay:**

This item allows you to enable/disable IR transmission delay.  
The choice: Enabled, Disabled.

**UR2 Duplex Mode:**

This item allows you to select the IR half/full duplex function.  
The choice: Half, Full.

**Use IR Pins:**

This item allows you to select IR transmission routes, one is RxD2m, TxD2 (COM Port) and the other is IR-Rx2Tx2.  
The choice: IR-Rx2Tx2, RxD2 and TxD2.

**Onboard Parallel Port:**

This item allows you to determine access onboard parallel port controller with which I/O address.  
The choice: 3BC/IRQ7, 378/IRQ7, 278/IRQ5 and Disabled.

**Parallel Port Mode:**

Select an operating mode for the onboard parallel (printer) port. Select Normal, Compatible, or SPP unless you are certain your hardware and software both support one of the other available modes.  
The choice: SPP, EPP, ECP and ECP+EPP, Normal.

**EPP Mode Select:**

Select EPP port type 1.7 or 1.9.  
The choice: EPP1.7, 1.9.

**ECP Mode Use DMA:**

Select a DMA channel for the parallel port for use during ECP mode.  
The choice: 3, 1.

**PWRON After PWR-Fail:**

This item allows you to select if you want to power on the system after power failure.  
The choice: Off, On and Former-Sts.

### 3.8 Power Management Setup

The Power Management Setup allows you to configure your system to most effectively save energy while operating in a manner consistent with your own style of computer use.

Phoenix - AwardBIOS CMOS Setup Utility  
Power Management Setup

ACPI Function	Enabled	Item Help
Power Management	User Define	
Video Off Method	Blank Screen	
Video Off In Suspend	No	Menu Level >
Suspend Type	Stop Grant	
MODEM Use IRQ	3	
Suspend Mode	Disabled	
HDD Power Down	Disabled	
Soft-Off by PWR-BTTN	Instant-Off	
CPU THRM-Throttling	50.0%	
Power On by Ring	Disabled	
Wake Up On Lan	Disabled	
Resume by Alarm	Disabled	
X Date (of Month) Alarm	0	
X Time (hh:mm:ss) Alarm	0 0 0	
**Reload Global Timer Events**		
Primary IDE 0	Disabled	
Primary IDE 1	Disabled	
Secondary IDE 0	Disabled	
Secondary IDE 1	Disabled	
FDD, COM, LPT Port	Disabled	
PCI PIRQ [A-D]#	Disabled	
↑↓→←Move Enter: Select +/-/PU/PD: Value F10: Save ESC: Exit F1: General Help F5: Previous Values F6: Fail-safe defaults F7: Optimized Defaults		

#### ACPI Function:

This item allows you to enable/disable the Advanced Configuration and Power Management (ACPI).

The choice: Enabled, Disabled.

**Power Management:**

This category allows you to select the type (or degree) of power saving and is directly related to the following modes:

1. HDD Power Down
2. Doze Mode
3. Suspend Mode

**Min. Power Saving:**

Minimum power management. Doze Mode = 1 hr. Standby Mode = 1 hr., Suspend Mode = 1 hr., and HDD Power Down = 15 min.

**Max. Power Saving:**

Maximum power management -- **ONLY AVAILABLE FOR SL CPU's.** Doze Mode = 1 min., Standby Mode = 1 min., Suspend Mode = 1 min., and HDD Power Down = 1 min.

**User Defined:**

Allow you to set each mode individually. When not disabled, each of the ranges is from 1 min. to 1 hr. except for HDD Power Down, which ranges from 1 min. to 15 min. and disable.

**Video Off Method:**

This determines the manner in which the monitor is blanked.

**V/H SYNC+Blank:**

This selection will cause the system to turn off the vertical and horizontal synchronization ports and write blanks to the video buffer.

**Blank Screen:**

This option only writes blanks to the video buffer.

**DPMS:**

Initial display power management signaling.

**Video Off Method:**

This item allows you to on/off Method function.

The choice: Yes, No.

**Video Off In Suspend:**

This determines the manner in which the monitor is blanked.

The choice: Yes, No.

**Suspend Type:**

Select the Suspend Type.

The choice: PwrOn Suspend, Stop Grant.

**MODEM Use IRQ:**

This determines the IRQ in which the MODEM can use.

The choice: 3, 4, 5, 7, 9, 10, 11 and NA.

**Suspend Mode:**

When "Enabled" and after the set time of system inactivity. All devices except the CPU will be shut off.

The choice: Disabled, 1, 2, 4, 8, 12, 20, 30, 40 Min and 1Hour.

**HDD Power Down:**

When "Enabled" and after the set time of system inactivity, the hard disk drive will be powered down while all other devices remain active.

The choice: Disabled, 1~15Min.

**Soft-Off by PWR-BTTN:**

Pressing the power button for more than 4 seconds forces the system to enter the Soft-Off state when the system has "hung."

The choice: Delay 4 Sec, Instant-Off.

**CPU THRM-Throttling:**

Select the CPU THRM-Throttling rate.

The choice: 25.0%, 50.0%, 75.0%.

**Power On by Ring:**

An input signal on the serial Ring Indicator (RI) line (in other words, an incoming call on the modem) awakens the system from a soft off state.

The choice: Enabled, Disabled.

**Wake Up On Lan:**

An input signal from Lan awakens the system from a soft off state.

The choice: Enabled, Disabled.

**Resume by Alarm:**

When "Enabled", you can set the date and time at which the RTC (real-time clock) alarm awakens the system from Suspend mode.

The choice: Enabled, Disabled.

**Reload Global Timer Events:**

The events are I/O events whose occurrence can prevent the system from entering a power saving mode or can awaken the system from such a mode. In effect, the system remains alert for anything, which occurs to a device, which is configured as Enabled, even when the system is in a power down mode.

Primary IDE 0  
Primary IDE 1  
Secondary IDE 0  
Secondary IDE 1  
FDD, COM, LPT Port  
PCI PIRQ [A-D] #

### 3.9 PnP/PCI Configurations

This section describes configuring the PCI bus system. PCI, or **Personal Computer Interconnect**, is a system, which allows I/O devices to operate at speeds nearing the speed the CPU itself uses when communicating with its own special components. This section covers some very technical items and it is strongly recommended that only experienced users should make any changes to the default settings.

#### Phoenix - AwardBIOS CMOS Setup Utility

##### PnP/PCI Configurations

PNP OS Installed	No	Item Help
Reset Configuration Data	Disabled	
Resources Controlled By	Auto (ESCD)	Menu Level >
X IRQ Resources	Press Enter	
X DMA Resources	Press Enter	
PCI/VGA Palette Snoop	Disabled	
INT Pin 1 Assignment	Auto	
INT Pin 2 Assignment	Auto	
INT Pin 3 Assignment	Auto	
INT Pin 4 Assignment	Auto	
↑↓→← Move Enter: Select +/-/PU/PD: Value F10: Save ESC: Exit F1: General Help F5: Previous Values F6: Fail-safe defaults F7: Optimized Defaults		

#### PNP OS Installed:

Select Yes if you are using a Plug and Play capable operating system.  
Select No. if you need the BIOS to configure non. Boot devices.

#### Reset Configuration Data:

Normally, you leave this field Disabled. Select "Enabled" to reset Extended System Configuration Data (ESCD) when you exit Setup if you have installed a new add-on and the system reconfiguration has caused such a serious conflict that the operating system cannot boot.

The choice: Enabled, Disabled.

#### Resources Controlled By:

It allows you can automatically configure all the boot and Plug and Play-compatible devices. If you select Auto, all the interrupt request (IRQ) and DMA assignment fields disappear, as the BIOS automatically assigns them.

**IRQ/DMA Resources:**

When resources are controlled manually, assign each system interrupt a type, depending on the type of device using the interrupt.

**PCI/VGA Palette Snoop:**

Leave this field at "Disabled".

The choice: Enabled, Disabled.

**INT Pin 1~Pin 4 Assignment:**

These items allow you to specify what IRQ will be assigned.

The choice: Auto, 5, 9,10,11.

### 3.10 PC Health Status

Phoenix - AwardBIOS CMOS Setup Utility

#### PC Health Status

		Item Help
CPU Warning Temperature	Disabled	
Current System Temp.	33°C / 91°F	
Current CPU Temperature	38°C / 100°F	
Current CPUFAN Speed	3835 RPM	
Current System FAN Speed	4725RPM	
VDIMM :	2.48V	
Vcore :	1.45V	
+3.3V	3.37V	
+ 5 V	5.08V	
+12 V	11.91V	
VBAT (V)	3.24V	
Shutdown temperature	Disabled	
↑↓→←Move Enter: Select +/-/PU/PD: Value F10: Save ESC: Exit F1: General Help F5: Previous Values F6: Fail-safe defaults F7: Optimized Defaults		Menu Level >

#### CPU Warning Temperature:

This item will prevent CPU from overheating.

The choice: 50°C /122°F ~70°C /158°F, Disabled.

#### Current System Temp:

Show you the current system temperature.

#### Current CPU Temperature:

Show you the current CPU temperature.

#### Current CPUFAN Speed:

Show you the current CPU fan operating speed.

#### Current System FAN Speed:

Show you the current system fan operating speed.

#### VDIMM:

Show you the voltage level of the DRAM.

**Vcore:**

Show you the voltage level of CPU (Vcore).

**+3.3V/+5V/+12V:**

Show you the voltage of +3.3V/+5V/+12V.

**VBAT (V)**

Show you the voltage level of the battery.

**Shutdown Temperature:**

This item allows you to set up the CPU shutdown Temperature.

The choice: Disabled, 60°C / 140°F, 65°C / 149°F, 70°C / 158°F and  
75°C / 167°F.

### 3.11 Frequency/Voltage Control

Phoenix - AwardBIOS CMOS Setup Utility

Frequency/Voltage Control

Auto Detect PCI Clk	Enabled	Item Help
Spread Spectrum	Disabled	
		Menu Level >
↑↓→←Move Enter: Select +/-PU/PD: Value F10: Save ESC: Exit F1: General Help F5: Previous Values F6: Fail-safe defaults F7: Optimized Defaults		

#### Auto Detect PCI CLK:

When "Enabled", this item will auto detect if the PCI socket have devices and will send clock signal to PCI devices. When disabled, it will send the clock signal to all PCI socket.

The choice: Enabled, Disabled.

#### Spread Spectrum:

This item allows you to set the spread spectrum modulated.

The choice: +/- 0.35%, +/- 0.50%, +/- 0.75%, +/- 1.0%, Disabled.

### 3.12 Load Fail-Safe Defaults

When you press <Enter> on this item you get a confirmation dialog box with a message similar to:

Load Fail-Safe Defaults (Y/N)? **N**

Pressing “Y” loads the BIOS default values for the most stable, minimal-performance system operations.

### 3.13 Load Optimized Defaults

When you press <Enter> on this item you get a confirmation dialog box with a message similar to:

Load Optimized Defaults (Y/N)? **N**

Pressing “Y” loads the default values that are factory settings for optimal performance system operations.

### 3.14 Supervisor/User Password Setting

You can set either supervisor or user password, or both of them. The differences between are:

**Set Supervisor Password:** can enter and change the options of the setup menus.

**Set User Password:** just can only enter but do not have the right to change the options of the setup menus. When you select this function, the following message will appear at the center of the screen to assist you in creating a password.

#### ENTER PASSWORD:

Type the password, up to eight characters in length, and press <Enter>. The password typed now will clear any previously entered password from CMOS memory. You will be asked to confirm the password. Type the password again and press <Enter>. You may also press <Esc> to abort the selection and not enter a password.

To disable a password, just press <Enter> when you are prompted to enter the password. A message will confirm the password will be disabled. Once the password is disabled, the system will boot and you can enter Setup freely.

#### PASSWORD DISABLED.

When a password has been enabled, you will be prompted to enter it every time you try to enter Setup. This prevents an unauthorized person from changing any part of your system configuration.

Additionally, when a password is enabled, you can also require the BIOS to request a password every time your system is rebooted. This would prevent unauthorized use of your computer.

You determine when the password is required within the BIOS Features Setup Menu and its Security option (see Section 3). If the Security option is set to "System", the password will be required both at boot and at entry to Setup. If set to "Setup", prompting only occurs when trying to enter Setup.

### 3.15 Exit Selecting

#### Save & Exit Setup

Pressing <Enter> on this item asks for confirmation:

**Save to CMOS and EXIT (Y/N)?**  Y

Pressing “Y” stores the selections made in the menus in CMOS – a special section of memory that stays on after you turn your system off. The next time you boot your computer, the BIOS configures your system according to the Setup selections stored in CMOS. After saving the values the system is restarted again.

#### Exit Without Saving

Pressing <Enter> on this item asks for confirmation:

**Quit without saving (Y/N)?**  Y

This allows you to exit Setup without storing in CMOS any change. The previous selections remain in effect. This exits the Setup utility and restarts your computer.

